

# AgKing

## AK Series Wheeled Tractor Operations Manual

Suitable for AK404 tractor.



# User Guide

## **Dear Customer,**

Thank you for choosing AgKing to provide you with your new equipment. We appreciate your business and look forward to a continued relationship and to help you get the most from your equipment.

To assist in the safe and effective use of this equipment please read and understand this important information, even if you have prior experience of other tractors these instructions will help you to be more efficient and safe.

1. To prolong the service life of this equipment please also read and understand the service manual requirements and strictly comply with the regulations in the manual.
2. Please do not modify the equipment in any way contrary to the information specified in this manual as doing so could void warranty and cause dangerous situations to arise.
3. Understand there is a great degree of variation to the soil conditions and environment conditions in various regions. The operational efficiency as well as the parameters of various implements and attachments may be different in your specific conditions. Please consider options suitable for your situation.
4. This equipment should be operated, maintained and repaired only by people who are familiar with this equipment characteristics and safe operations.
5. Operators of this equipment must have relevant experience or licenses for the operation of this class of equipment. It is the operator/owners responsibility to ensure any operators of this equipment are sufficiently trained and licensed.
6. At any time while operating this equipment and where relevant, all traffic regulations must be followed.
7. The contents of this manual are relevant to the equipment at the time of publication. Changes and updates about safety improvements will be made to without notice. Customers should update the operators manual from the website to keep up to date with latest improvements.
8. This operation manual is not a product warranty.

# Overview

This manual details the safety precautions, running in and use of functional parts, as well as technical maintenance, adjustments and also faults and solutions for the specified parts in detail. It can be taken as the reference for operators and repairers of the equipment.

In this manual you will come across a safety alert sign.  This indicates important safety information. When you see this sign it is to alert you to possible harm from incorrect use. Please carefully read the information provided with these warning signs and notify other operators if relevant.



**Warnings:** Indicate that if not avoided, dangerous situations with serious or possibly fatal injuries could occur.



**Notes:** Indicate that if not avoided, dangerous situations with low to moderate degree of injuries could occur.

**Important:** Describes items that may cause damage or harm to equipment or environment.

**Note:** Additional important information.

Please read this manual carefully prior to operating this equipment. This manual constitutes a part of the product. It will be provided with the product and should be kept for reference as appropriate.

Tractors are an essential tool that are needed to help with maintenance of rural properties, agricultural production and many other applications. From building fire breaks to trenches and roads a tractor can be a life saver. However tractors are powerful tools that can be very dangerous to operate unless the operator is trained and experienced.

The range of possible uses and capabilities of the tractor will depend on the experience and knowledge of the operator. The supplier or dealer who sells the tractor may not be experienced on the applications and use of the tractor on your land. You as the owner or operator of the tractor must satisfy yourself that the tractor is suitable and safe for the work you intend.

The seller does not offer recommendations or instructions on use or operation of the tractor on customers land without fully understanding the full environmental and geographical conditions of the land at the time of use.

AG King does not offer on site driver training or advice to customers on how to operate the tractor on their land. The seller may offer training and advice on how to operate the tractor at the sellers

display yard and the training is limited to tractor features, functions and theoretical capabilities. Owner / drivers must seek specific training or instruction based upon the local conditions of operation on their premises.

As a general rule we recommend that if the operator is not trained or experienced to operate the tractor to complete a specific task then do not do the job. Seek advice or help.

The University of Queensland, Gatton does offer tractor driver training and may be able to arrange suitable driver training.

## Intended Use

The AgKing AK404 wheeled tractor are a compact size agricultural wheeled tractor designed for multiple uses. The main characteristics are compact structure, simple technology, easy operation, good traction force, fitted with rear lifter and PTO drive shaft.

Note - Front End Loaders are an optional additional implement fitting and are not part of the tractor. You must refer to the operations manual for the front end loader.

Warning – Front End Loaders change the original specification and capabilities of the tractor by increasing weight, reducing rear wheel traction, reduce stability and in general should only be used on flat level ground. Do not use loaders on hills or slopes, specially when descending. Refer to the Loader operations instructions for more specific warning and understanding of the limitations.

The driver operator of this tractor is expected to fully understand the functions of the tractor and to only operate the tractor in conditions and circumstances that are safe. The driver is expected to be mature, experienced and well informed on tractor driving methods and safety conditions. Persons with limited driving experience should not drive the tractor until they are fully trained.

This tractor should only be operated, maintained and repaired by a person who is familiar with the tractor's characteristics and has knowledge of relevant safe operations. The driver is expected to understand speed gear ratios of High and Low and how and when to apply the correct gear for operational conditions. The driver must be satisfied they have the experience and knowledge needed to operate the tractor safely.

The tractors fitted with front end loaders are intended to be used on solid level ground and should not be used on hill slopes or in any conditions where stability is compromised. The four wheel drive should be engaged on unstable ground and when negotiating slopes, rough uneven ground, sandy, wet dirt road conditions or when maximum traction force is required. The four wheel drive is not constant and should not be engaged unless necessary and 4 wheel drive should be disengaged after use. Do not use 4 wheel drive on sealed roads or none slip surfaces.

When equipped with the appropriate implements, this tractor can be used for operations such as slashing, raking, sowing, harvesting, ploughing, mowing, lifting, digging, drilling, crop spraying,

clearing and more. The power take off shaft can be used to operate many implements, such as slashers, balers, pumps and rotary ploughs.

The tractor should not be used in conditions that may cause risk of injury or damage to person or property. The driver of the tractor is expected to have experience and knowledge to operate the tractor safely.

Open air ROPS tractors are not suitable for use with hazardous chemical substances. (e.g. spraying of pesticides. If you intend to spray chemicals seek professional advice about safe application.

Users must strictly comply with the conditions of use, maintenance and repair as specified by the manufacturer.

The tractor may only be operated on roads if the tractor is registered for road use and provided the operator is experienced and licensed or qualified to drive on roads.

The tractor must not be modified or changed in structural design because doing so will void the manufacture warranty.

## Chinese-English Comparison List for Common Units

No.	Unit Category	International Unit	Unit Name
1	Time	s	seconds
2		min	minutes
3		h	hours
4	Length	mm	millimetres
5		cm	centimetres
6		m	meters
7		km	kilometres
8	Force	N	Newtons
9		kN	Kilo newtons
10	Moment of Force	N-m	Newton meters
11	Mass	kg	kilograms
12		g	grams
13	Pressure	Pa	pascal
14		kPa	kilo pascal
15		MPa	mega pascal
16		kgf/cm <sup>2</sup>	Kilogram per square cm
17	Temperature	C	Celsius
18	Speed	km/h	Kilometres per hour
19	Rotational speed	r/min	Revolutions per minute
20	Electric current	A	Amps
21	Voltage	V	Volts
22	Volume	L	Litres
23		ml	millilitres
24	Flow rate	L/min	Litres per minute
25	Power	kW	kilowatt
26		PS	pferdestarke
27	Fuel consumption	g/kW-h	Grams per kilowatt hour
28	Accumulator Capacity	Ah	Amp hours

# 1. Safety Precautions

## 1.1 Safe Rules and Use Precautions

### Must read before operating

1. The use and maintenance instruction manual and the safety warning signs should be read and understood completely before operating the tractor.
2. The tractor should only be used when conditions are safe to operate the tractor.

### Qualified Operator

1. The driver must have experience and knowledge about using the tractor and must consider the terrain and circumstances safe to operate. The driver operator takes sole responsibility for how to operate the tractor. If any job or task appears to be unsafe or risky the driver must stop the job and seek experienced advice. Think twice before you act!
2. Any persons who are unwell, drunk, tired, pregnant or under an appropriate age should not be allowed to operate the machinery.
3. The driver must be trained and experienced and where local laws apply should have a drivers license.
4. When learning to operate the tractor the driver should operate the machinery on level ground at low speed and have a trained person ready to help.
5. The driver operator must do a physical check of the tractors condition before operations start and after operations are complete. Refer to the schedule of before and after checks.
6. The driver should only enter or exit the tractor when the engine is stopped and the tractor is parked in a safe location with the park brake fully enabled.
7. The driver must engage and use the seat belt before driving.

### Wear appropriate clothing

During the operation, the driver should wear appropriate and tight fitting working clothing. Loose fitting jackets or shirts, baggy or loose fitting pants as well as accessories such as ties should not be worn while operating the machinery as it could present a risk of being caught in moving parts.

### Use of fuel / oils

1. The fuels and oils used for this machine are flammable. Therefore avoid open flames and fireworks while fuel is being used.
2. Before refuelling the tractor the engine must be turned off and the tractor parked safely.
3. Smoking is strictly prohibited during the refuelling and/or maintenance of the fuel system.
4. Spilt fuel or oil must be cleaned off using a clean rag prior to operating the machine.
5. The quality of fuel and lubricating oil should be in strict accordance with the requirements shown in the "Appendices".

**NOTE:** It is forbidden to put flammable and explosive objects near the fuel or oil tank inlets.

### Disposal of waste oil

1. Replaced/used engine oil is considered toxic waste and can not be discarded at will. Please follow local regulations for disposal of toxic chemicals.

2. The replaced accumulator acid is toxic for the environment, so cannot be discarded at will. Please follow local regulations for disposal of toxic chemicals.

### **Leaking oil pipe**

Oil leaking from high pressure oil pipes should not be touched with hands at risk of injury. Paper / cardboard, dry talcum powder can be used to detect position of leaking oil if it cannot be clearly seen.

### **Emergency handling**

1. If brakes fail , control the steering to avoid obstacles, turn the engine off and allow gear compression to stop the tractor.
2. If the steering wheel is out of order, put on the brakes immediately and shut down the engine when safe to do so.
3. If the machine is on fire, shut down the engine and extinguish the flame immediately. If a fire extinguisher is available, aim it at the base of the flame. If not, use sand, dirt, thick blanket or some other way of starving the fire.
4. After an accident, if needed, dial the emergency services as appropriate.

### **Correct support of tractor**

1. Parts or implements fails refer to the supplier for replacement.
2. Do not use cinder block, air brick, tiles or other supports which can crumble under persistent weight.
3. Do not work under a tractor which is supported by a single jack.
4. Before operating a jack it is necessary to read the operation manual. It is forbidden to overload the jack. The jack should be on firm ground to prevent injury, death or property loss.
5. The jack should be positioned below the rear axle left and the right semi-shaft shell or the front support. Other areas should not be used to jack the tractor.

### **Cautions for installation of rear implements**

1. When installing rear implements or trailers the engine should be stopped and the tractor parked in a safe location with the handbrake engaged. Please consult the implements instructions for installation and any operators manuals or warning signs as required.
2. The installation should be carried out according to the relevant operating manual. The tractor should not be operated until the installation of the implement is fully completed.
3. Injury is possible if the person installing the implement does not have experience so where relevant a professional should be consulted.
4. The implement should be fully installed and on the ground before being left unattended.
5. People should keep away from the area around implements while the implement is in use.





## Warnings

1. For the safety of your life and property, and the happiness of your loved ones, please operate safely.
  2. When starting the tractor, pay attention to whether there are obstacles on the road as well as whether there is someone between the tractor and the farm implements or trailer. If required, signal warning them to prevent unexpected accidents caused by the sudden start of tractor.
  3. Do not leave the driver seat position to start and manipulate the tractor. During the starting of tractor, ensure that the gear lever is placed in the position of neutral gear, the power take-off control handle and the front driver control handle is in the state of separation, and the lifter control handle is placed in the position of neutral gear, thus to prevent unexpected accidents caused by the sudden start of tractor.
  4. Do not start the engine by using the method of bridging the short circuit binding post, otherwise, when the gearbox is put in gear, the walking of the tractor will be out of control automatically, thus leading to unexpected accidents.
  5. The movement of each pedal should not be hindered and all the pedals must be able to return to the original position without hindering. Do not place any object that will hinder the pedal path on the floor and under the pedal. Do not place the articles which will roll or slide when moving the pedal. Do not place additional foot carpet or other bedding around the pedal, to avoid unexpected accidents caused by the influence on the movement of the pedal.
  6. During the running of the tractor, nobody is allowed to get on or off the tractor. During the operating of the engine, do not carry out the examination and repair under the tractor, to avoid unexpected accidents.
  7. After the tractor is stopped and before the driver gets off the tractor, be sure to take out the key, shift each gear lever to the position of neutral gear, and lock the parking brake handle tightly, to avoid unexpected accidents caused by the sudden start and automatic movement out-of-control of the tractor.
  8. During the transportation operation, the left and right brake pedals must be interlocked. Control the speed reasonably. When passing through culverts and bridges, note that whether it is extra-high, and decelerate it sufficiently in advance when changing direction and turning, to avoid rollover and crash due to the occurrence of unexpected situations.
  9. When running on an up-slope or a down-slope, adopt the lowest gear, and rationally apply the throttle control. It is strictly forbidden to let the tractor slide downhill with the gear put in the neutral position or the clutch pedal pressed down, and the gear-shifting is strictly prohibited when running on an up-slope or a down-slope, in order to avoid rollover.
  10. Sudden turn is not allowed when the tractor is running at a high speed. Do not take a sudden turn by using one-side braking, in order to avoid rollover.
  11. When the tractor is running on the road, pay attention to the traffic signs, and abide by the traffic regulations strictly, to avoid unexpected danger.
  12. During transferring, abide by the traffic regulations strictly. The distance between 2 vehicles should be maintained as 60m at least, to avoid the occurrence of rollover and unexpected accidents.
1. The roadbed around the ditches, holes, and dam is relatively weak, and the weight of the tractor may make it collapse. Please bypass it. Otherwise, unexpected accidents may occur.
  2. The tractor should not be overloaded, and the ultra-extreme working is strictly prohibited, to avoid machine damage or even personal casualty due to the overloading of machine parts.
  3. When the tractor is working at night, there should be good lighting equipment to prevent the influence on the working effect of the tractor and the occurrence of unexpected dangerous accidents.

4. During the harvesting operation or yard work of the tractor, the spark elimination device should be installed in the vent-pipe to avoid unexpected fire hazards.
5. When operating in the rainy and snowy days, the operating speed must be reduced to avoid rollover risk due to the slippery roads and floor.
6. When conducting the power take off operation, ensure that the connections and shelters are reliable, thus to prevent people being hurt by the taking off of moving parts.
7. During the articulating and traction of implements, ensure that each pin connection is reliable and firm, to avoid a collision caused by pin falling. When the pins come off from the articulating and traction implements, ensure that all pins are under the state of separation, to prevent the machine damage and personal safety hazards caused by unclear separation.
8. During lifting, pay attention to the control of engine accelerator, avoiding the machine damage or personal safety danger due to the fast lifting speed.
9. During the charging of the accumulator, ensure that the vent-hole of the filler plug is unlocked, and the accumulator is far away from the open fire. After the charging is finished, cut off the power supply first to prevent explosion.
10. Abide by the safety height allowed by the high voltage transmission line strictly, to avoid the occurrence of unexpected dangerous accidents!
11. Don't use the tractor when it has the danger to turn over in dangerous area.
12. Just when the tractor finishes working, it is necessary to prevent oil heat surface to splash when people add oil or coolant to engine or transmission.
13. When operate three-point hitch, people should keep away from the hitch working area.
14. The implement should has already fallen to the ground before disconnecting it from tractor.
15. According to the function of implement and trailer, the user can adjust PTO speed through PTO shift. PTO speed is 540/760 or 540/1000.
16. When using PTO drive shaft, it is necessary to remove PTO shaft-end cover and make sure that protecting cover installs correctly in the working area.



### Notes

1. The bolts, nuts, and releasable parts of each connection, such as the fixing nuts of the front and rear drive wheels and connection nut of the steering tie rod, should be checked regularly. If any looseness is found, screw it up to avoid unexpected dangerous accidents;
2. When the power take off shaft of the tractor is working, the protective cover for the power take off shaft must be installed. It is strictly prohibited from approaching the power take off shaft. When the power take off shaft is on load, the tractor can not take a sudden turn to avoid damage to the universal joints or the power take off shaft of the tractor; when the power take off shaft is not working, the handle should be in the position of separation to avoid unexpected dangerous accidents;
3. After the tractor is stopped and before the engine has not been flamed out, the driver should not leave the tractor to prevent unexpected accidents caused by the sudden start and automatic movement out-of-control of the tractor;
4. The tractor has to be parked on slopes, the hand brake handle should be in a working state. Shut down the engine, put in gear (shift to the forward gear in the uphill position and shift to the reverse gear in the downhill position), and be sure to use the parking brake and the triangular block to plug the rear wheel, thus to prevent unexpected accidents caused by the automatic movement out-of-control of the tractor;
5. Installation and adjustment of tires only can be done by experienced professionals using appropriate special tools, and incorrect installation of tires may lead to serious accidents;

6. When cleaning the water tank, first extinguish the flame and shut down the engine, and clean it after it is cooled, thus to avoid burn accidents and water tank damage;
7. Before the installation and use of the selected parts for installation, replacement parts or articulating implements, please pay attention to safety and read the safety signs and instruction manual carefully.

### **Important Items**

1. As for the tractors that have just left the factory or are overhauled, the running in must be carried out according to the running in requirements for tractors;
2. Various solutions should be used for tractors in strict accordance with the requirements. The fuel should be used after precipitation and purification for 48h at least, and the lubricating oil for the transmission system should be filled only after being filtered by the filter with the same accuracy as the oil absorption filter of the lifter;
3. Before the starting of the tractor, the situations of oil circuit, electric circuit and cooling water must be checked; After the starting, attention should be paid to the readings of each instrument at all times;
4. Before using the driving farm implements of the power take off shaft, the rationality of the matching between the tractor and the driving farm implements should be checked. During farming, the included angle between the power take off shaft and the universal joint transmission shaft should not exceed 15°; when the hydraulic manipulation is normal, after the field edge turning and the farm implements lifting, the included angle between the power take off shaft as well as the farm implements take in shaft and the transmission shaft should not exceed 20°; before the power take off is connected, it is forbidden to put the rotary cultivator into the soil, because it would result in damage of the rotary cultivator and severe damage to the clutch of the tractor (to increase the operation efficiency, the power source may not be cut off when turning, but the implements lifting height must be around 200mm from the ground);
5. When the farm implements hung on the tractor are transferred, the positions of farm implements should be fixed; when the driver leaves the tractor, the farm implements must be lowered down to the ground certainly;
6. When the winter temperature is lower than 0°C, the antifreeze fluid must be applied;
7. The front drive axle of the tractor is only used when the tractor works in a farmland, the road is slippery and the tire slides; it is strictly forbidden to use in other situations, otherwise, it is easy to cause early abrasion of the tires and the transmission system;
8. The qualified spare parts must be chosen for the maintenance of the tractor.

### **Unscrewing the radiator cap**

Never remove the radiator cap when the engine is running or hot. When the engine has cooled use a cloth to insulate your hand and carefully unscrew the radiator cap. Always be aware of hot water under pressure.

### **Electrical Maintenance**

1. Before attempting any electrical maintenance, ensure the engine is off and the keys removed from the ignition switch to avoid accidental starting.
2. Perform maintenance on electric parts only after the leads have been disconnected from the battery.
3. It is dangerous to touch the battery electrolyte (dilute sulphuric acid). If eyes, skin and clothes touch the electrolyte, please wash with water immediately. If the electrolyte enters

into eyes, please wash with lot of water immediately, and then seek immediate medical attention.

### **Abnormal conditions in the tractors**

1. The tractor should be stopped and checked as soon as possible if there is a low or no oil pressure or the coolant temperature is too high or there is abnormal sounds or smells.
2. During any checking, lubrication or maintenance the tractor should be stopped in a safe location with the engine off and the park brake applied.

## 1.2 Safety warning signs



### **Notes:**

1. Safety warning signs should be kept clear and easily visible at all times. When they become dirty, they can be cleaned with soapy water and a rag.
2. If safety signs are damaged or lost they should be replaced immediately by contacting your dealer for replacement stickers.
3. If the parts containing safety signs are needing to be replaced, then the safety signs should be replaced at the same time.
4. The comments on the safety signs are for personal safety and should be carried out strictly.

## 2. Product Markings

<b>Nameplate</b> The product nameplate, an important identification for the tractor, is located on the right of instrument panel. When receiving the after-sale service, the service personnel may inquire and check the nameplate, so please don't damage or lose it, and do keep its content clear.	
--	--

<b>Engine information</b> The nameplate of the engine, an important and valid identification for the tractor's supporting power unit, is located on the top of the engine, as shown in the figure.	
---	--

When receiving after-sale service, the service personnel may check the nameplate, so please don't damage or lose it, and do keep its content clear.

**Complete type and factory No.**



As the tractor leaves the factory, complete type and factory No., should be engraved or print on the three engraved and printed position

### 3. Instructions



**Notes:** Correct operation of the tractor can fully exert the performance of the tractor; reduce the wear and tear of the tractor and prevent accidents; and guarantee that the operator can complete field and road operations with excellent quality, efficiency, low consumption and safety

Symbol	Meaning	Symbol	Meaning	Symbol	Meaning
	Security alert		Four wheel drive engaged		Horn
	High beam headlights		Dipped headlights		Fast
	Engine oil pressure		Battery charge		Slow
	Indicators		Washer		Position lamps
	Engine preheating		Rear wiper		Windscreen wiper
	Air filter blockage		Hydraulic oil filter		Failure/Fault of brakes
	Coolant temperature warning		Fuel oil mass		Parking brake

	Differential lock engaged		Emergency		Alarm lamp
---	---------------------------	---	-----------	---	------------

### 3.1 Product description

This manual introduces the usage, technical maintenance, adjustment, faults and solutions, etc. of the AK404 Series Wheeled Tractors. The AK404 Series Wheeled Tractor is a medium-sized agricultural wheeled tractor with multiple usages. This tractor has such characteristics as compact structure, convenient operation, flexible steering, large lifting power and convenient maintenance, etc.

### 3.2 Control mechanism and instruments

#### 3.2.1 Control mechanism

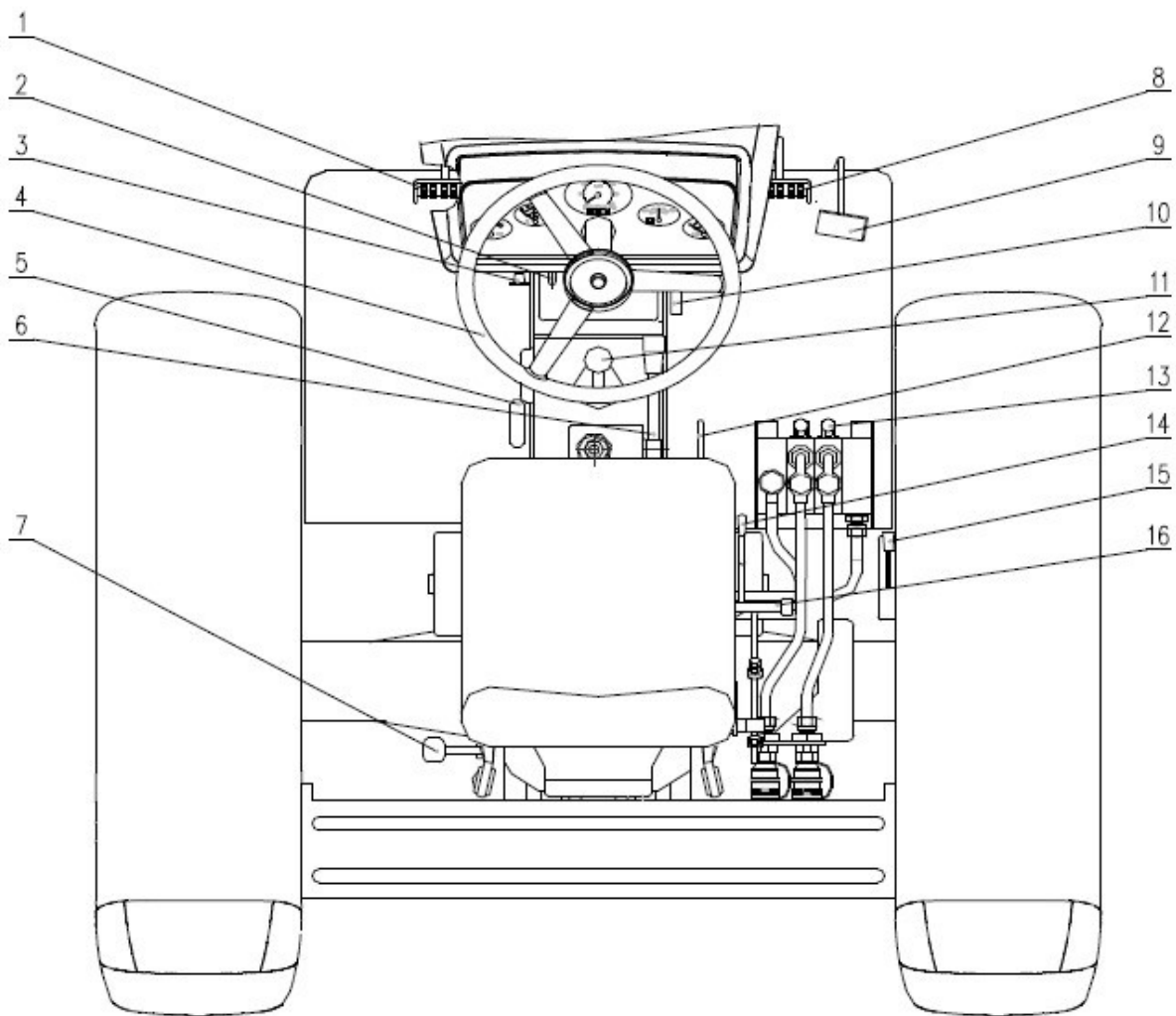

1. Clutch Pedal
2. Pressure-reducing Handle
3. Stall Stay Wire
4. Steering Wheel
5. Front Driving Axle Control Handle

6. Auxiliary Gear Lever
7. Power Take off Gear Shift Handle
8. Brake Pedal
9. Foot Accelerator Pedal
10. Park Brake Pedal
11. Main Gear Lever
12. Power Take off
13. Control Handle of Multi-way Valve
14. Differential Lock Control Handle
15. Hand Throttle Control Handle
16. Distributor Control Handle

### 3.2.2 Combination Instruments and Switches

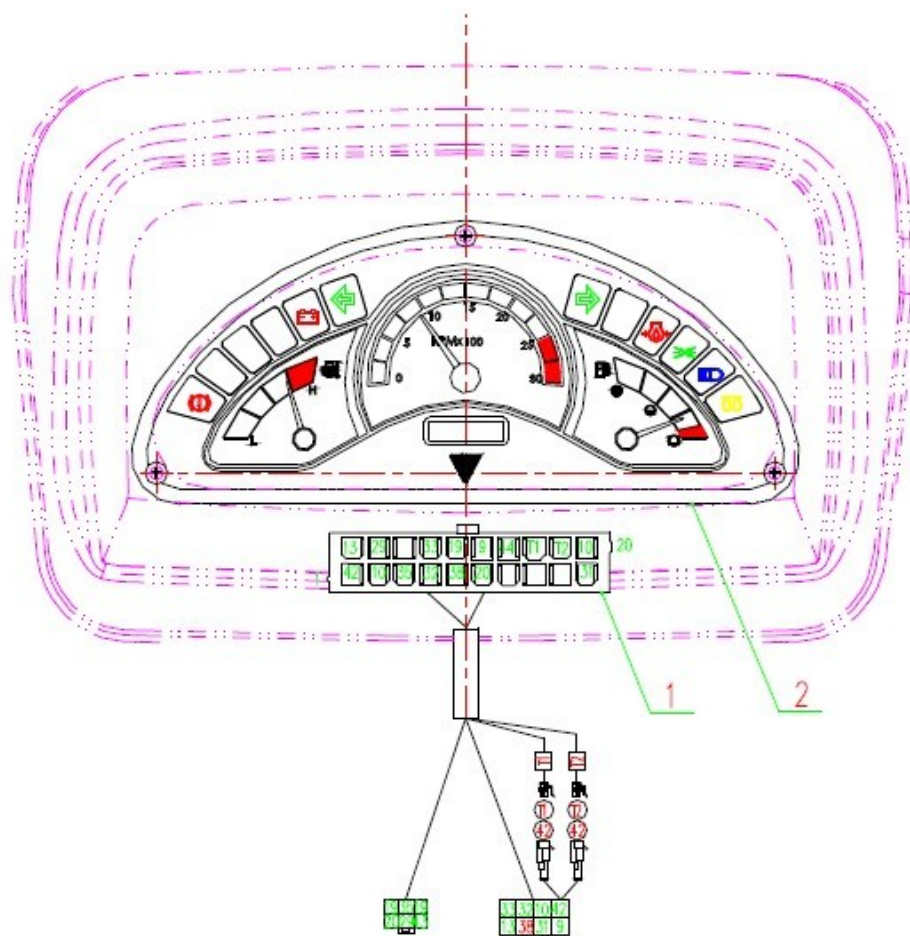

1. 1. Wiring harness assembly
2. 2. Combination instrument panel

Instrument type: TB450.487E.1 - Actuant (China) Industries Co.,Ltd.

Rated voltage: 12V









#### Technical parameters

Structure		Basic parameters							
Speed	Stepper	Value	r/min	500	1000	1500	2000	2500	3000

meter	motor	Permit difference	r/min	±0.1%								
	Structure	Basic parameters										
Water temp	Stepper motor	Value	°C	40	(50)	60	(70)	80	(90)	100	(110)	120
		coordinating resistance	Ω	297 ± 35	195.5 ± 22	135.3 ± 13.5	94.3 ± 8	67.7 ± 5	49 ± 4	36.5 ± 3	27.6 ± 2.5	21.1 ± 2

	Structure	Basic parameters													
Oil temp	Stepper motor	Value	capacity	1	7/8	3/4	5/8	1/2		3/8		1/4		1/8	0
		coordinating resistance	Ω	10	15	25.2	30.2	35.2	37.2	40.2	45.3	50.4	55.5	60.6	80.6

### Instrument warning indicators

Symbol	Left turn	Right turn	Battery	High beam	Position Lamp	Engine preheating	Failure/Fault of Brake	Oil Pressure
								
Colour	Green	Green	Red	Blue	Green	Yellow	Red	Red
Type	LED	LED	LED	LED	LED	LED	LED	LED

Each instrument panel indicator should be visible under sun but not glare or dazzle at night.

**Important:** When the tractor is operating, the driver shall always pay attention to various instruments and indicator lamps. In case of any abnormal situation, stop immediately and overhaul the tractor.

### Left rocker switch



1. Indicator switch
2. Working light switch

1. **Indicator switch** has three positions. Down (1) is the left indicator. Up (2) is the right indicator. Middle (0) is to switch off indicators.

2. **Working light switch** has three positions. Up (0) is lights off. Middle (1) is position lights on. Down (3) is position lights and rear lights are on.

### Right rocker switch



1. Headlight switch



## 2. Hazard light Switch

1. **Headlight switch** has three positions. Middle (0) is dipped headlights on. Up (1) is Backup. Down (2) is the high beam lights are on.

2. **Hazard switch** has two positions. Up is the hazard lights are off. Down is the hazard lights are on.

**NOTE:** Hazard lights can be used when it is necessary to warn the front and rear vehicles and pedestrians and draw their attention, in case that the tractor stops on the road due to some fault, or because of other reasons.

### Horn switch

This function can be used when it is necessary to warn the front and rear vehicles and pedestrians and draw their attention, in case that the tractor stops on the road due to some fault, or because of other reasons.	
---	--

### Ignition switch

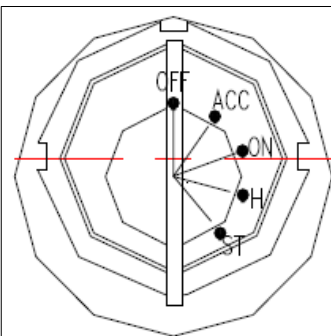

Rotating the preheating starting switch clockwise to ACC is to switch on the auxiliary electric appliance. Rotating it clockwise to ON is to switch on the control circuit. Rotating it clockwise to H is to switch on the pre-heater. After preheating, directly rotating it to ST is to start the engine. After the engine is started, let go of the switch immediately, and then the key is automatically back to ON. The duration of time when the switch stays in the starting position shall be less than or equal to 5s. Otherwise, the engine will be burned out.

## 3.3 Starting the engine



**Warning:** Before the tractor is used, it shall be checked carefully and comprehensively, so as to eliminate hidden hazards and prevent accidents effectively.

### 3.3.1 Preparations before starting the engine

- Before starting, check the tractor carefully to see whether the connection in all the parts is tight and reliable; whether each control mechanism works normally; whether the pipe joint in all the parts is tightened; and whether there is leakage of oil, water or air;
- Check the oil level of the lubricating oil in the engine oil pan, tractor gear box-rear axle and hydraulic system. The water tank radiator shall be filled with adequate cooling water. The fuel tank shall have enough fuel;

- Turn the handle of the oil circuit switch of the fuel tank to the position that is to the same direction of the oil pipe, so as to put the fuel oil circuit under the switch-on state;
- Check the control rods of the gear box and of the power take off shaft. Put the main gear lever, power take off control handle and front drive axle control handle in the neutral position. Put the distributor control handle in the fall position;
- Turn the locking device of the stall stay wire to loosen the stall stay wire. At this time, the oil injection pump is in the oil supply position;
- Put the manual accelerator in the half-open position;
- As for the tractor which is new, overhauled or unused for a long time, before starting, the air in the oil circuit shall be removed first, so as to guarantee the successful starting of the diesel engine. The method is described as follows: Firstly, loosen the air-bleed screw of the diesel filter. Press the oil pump to deflate the air in the oil circuit from the oil tank to the diesel filter until the deflated fuel is free of bubbles. Then tighten the air-bleed screw of the diesel filter. Loosen the air-bleed screw on the oil injection pump. Deflate the air in the same way mentioned above until the deflated fuel is free of bubbles.

**Important:**

1. Clean up the sundries in the mesh of the water tank regularly, so as to avoid the engine fault caused by poor heat dissipation;
2. After a backpack reaping machine is installed in the tractor, because of the poor radiating condition during field operation, it is recommended to install an auxiliary radiating device in the appropriate position of the tractor.

### 3.3.2 Starter Engine

**Important:**

1. After the engine is started, let go of the key immediately, and then the key is automatically rebounded back to position “ON” (See the picture of the ignition lock). Otherwise, the engine will reversely drive the starter and cause damage to the starter;
2. The attempted starting duration shall be less than or equal to 5s each time. After unsuccessful starting attempt please wait 15s or more before making another attempt. In order to maintain the charging performance of the battery, attempts at starting shall be no greater than 3 times. If the starting fails for 3 times, then find out the cause and start again.

#### 3.3.2.1 Starting using the battery

- Starting under normal temperature (when the temperature is above -5 C): Because the tractor has the safe starting switch, first step on the main clutch pedal. Then rotate the key to start the engine. Rotate the key clockwise to position “ON” to switch the circuit on, and then rotate the key to position “ST” to start the engine. After starting, let go of the key immediately, and then the key is automatically rebounded back to position “ON”.
- Preheating starting (only applicable to the type of tractor with preheating circuit): In case of lower temperature [below -5] when the cold starting is difficult, then the preheating starting can be adopted. Put the manual accelerator in the down position of the accelerator. Rotate the starting switch clockwise to the position “Preheat” and remain (15~20) seconds. Then rotate it to “ST” to start the engine. After starting, let go of the key immediately, and then the key is automatically rebounded. Then Put the manual accelerator in the up position of the accelerator. Before starting the tractor without preheating circuit in cold weather, fill the

water tank with the hot water of temperature above 90, until the hot water flows out from the water drain valve of the cylinder body. Then turn off the water drain valve and fill the whole cooling system full with hot water. Discharge the engine oil in the oil pan (It is better to discharge the oil when it is hot during last stall). Put the oil in the container with cover and heat in to (70~90). Then fill the oil in the oil pan again. It is forbidden to heat the oil pan with fire.

### 3.3.2 Starting tractor by traction

When the tractor is started by traction, ( push pull start ) the tractor under traction uses high III gear or high IV gear. To ensure safety the speed of traction of the tractor shall be less than or equal to 5 to 10 km/h.

**Note:** When the tractor is started by traction, once the engine runs, depress the main clutch pedal and reduce the accelerator. ( lower the RPM to idle )

### 3.3.3 Running of Engine

- After the engine is started, reduce the accelerator immediately to make the engine run in an idle speed. Check the oil pressure of the engine to ensure that the oil pressure gauge is in the normal range. In case of too high or too low pressure, stop the engine and check;
- After the engine is started, the engine shall not run with full load immediately. It shall run without load in a medium speed and be heated. Only when the temperature of the coolant reaches above 60, can the engine run with full load in a maximum rotational speed;
- Increase and reduce the rotational speed and load of the engine slowly, especially for the engine that has just been started. It is not allowed to step on the accelerator constantly and run in a high speed;
- When the engine is running, check the engine oil pressure and coolant temperature frequently;

**Important:** When the engine is running the oil pressure gauge must indicate normal pressure. A red light or buzzing sound is indication of low pressure. Stop the engine and find out the causes.

### 3.4 Starting the tractor

- The engine is in a low-speed state. Step on the clutch pedal, and then turn the gear shift lever of the gear box to the required gear;
- Press down the parking brake handle;
- Press the horn and observe whether there is any obstacle around;
- Increase the rotational speed of the engine gradually. Loosen the clutch pedal slowly and make the tractor start smoothly. After the tractor is started, loosen the clutch pedal quickly, so as to avoid the sliding and wear of it;
- Step on the accelerator gradually to make the tractor reach the required running speed;
- When the tractor is being operated, it is not advised to reduce its running speed through semi-clutching the clutch. During running, do not step on the clutch pedal all the time, so as to avoid accelerating the wear and tear of the disengaging lever and friction plate.

**Important:** In order to prevent the teeth collision of transmission gears in the gear box, it is strictly forbidden to use high gear to start. Before starting, loosen the parking brake, so as to avoid damaging its working parts.

## 3.5 Steering of tractor

**3.5.1** When operating the tractor on the road, first operate the horn switch to warn other vehicles that you are operating. Be sure to use indicators appropriately then steer the tractor. **DO NOT** attempt to turn corners at high speed as this could cause the tractor to roll. If the corner is gentle, rotate the steering wheel early and slowly. If the corner is sharp, rotate the steering wheel lately and quickly.

**3.5.2** When the tractor turns a small corner or turns around on the soft land, as the steering may fail due to the side slip of the front wheels, step the brake pedal on the corresponding side when rotating the steering wheel to help the steering.



### Warnings:

1. When the tractor runs in a high speed, do not make a sharp turn by one-side brake. When the front wheel turns a large corner, if any squeak occurs because the safety valve works, then the steering wheel shall rotate back a little to avoid that the hydraulic steering system may overload for a long time, thus causing failure in steering and accidents;
2. Before the tractor turns around or reverses during field operation, do lift the embedded working parts of the agricultural machinery out of the ground, so as to avoid damaging the agricultural implement or causing personnel casualty accidents.

## 3.6 Gear shifting of tractor

### 3.6.1 8+8 Shuttle-type Gear

- 8 gears can be achieved for the main gear lever and auxiliary gear lever respectively by a control rod. The main gear lever can get 4 gears (1, 2, 3 and 4). The auxiliary gear lever can get 2 speed sections (L is low-speed section and H is high-speed section).
- Step on the clutch pedal and manipulate the auxiliary gear lever. Push the auxiliary gear lever from neutral position to high gear H. Pull it back to low gear L.
- Step on the clutch pedal. Push the main gear lever from neutral position to gear 1. Pull it back to gear 2. Shift it from neutral position to left, then to back to gear 3. The forward shift will get to gear 4.
- The shuttle-type gear control handle of the tractor is on the upper left part of the instrument desk. To push forward is forward gear. To pull back is backward gear. To combine with the main gear lever and auxiliary gear lever can get 8 forward gears and 8 backward gears.
- To select the working speed of the tractor correctly can not only achieve optimum productivity and economical efficiency, but also prolong its service life. The tractor shall not often overload when working. The engine shall have a certain power reserve. It is better that the selected field working speed of the tractor shall make the engine work under around 80% load. If the tractor works under light load and low working speed, then select high 1 gear in the up position of the accelerator to work, so as to save the fuel.

## 3.7 Operation of differential lock

When the tractor is running or operating, in case of trap or one-side drive slip that causes failure of forwarding of the tractor, joint the differential lock to connect the left and right drive shafts rigidly according to the following procedures, so that the tractor can drive out of the slipping area at the same rotational speed of the left and right drive shafts.

- Step on the clutch pedal, and then operate and shift the gear lever to the low-speed gear.
- Turn the accelerator control handle to the maximum oil supply position.
- Step on the differential lock pedal on the lower right part of the driver seat.
- Loosen the clutch pedal smoothly to make the tractor start smoothly.
- When the tractor runs off the slip area, loosen the differential lock pedal and make it back to its position.

**Important:** When the tractor is normally running and turning around, it is strictly forbidden to use the differential lock, so as to avoid damaging the machine parts and accelerating the wear and tear of the wheels.

## 3.8 Use of the front drive axle

AK404 Series 4-wheeled Tractors are used for heavy-load operation in the fields or the work on the damp and soft soils. If they are only driven by the rear wheel, the traction property of the tractors may be insufficient. At this time, the connection of the front drive axle can increase the traction of the tractor and reduce the slip ratio, thus improving the adaptability for the operation of the tractors. In order to facilitate the joining and separation of the front drive axle, the following control procedures shall be followed:

### Connection of Front Drive Axle

Step on the clutch pedal. Put into gear of the gear box. Then release the clutch pedal slowly. When the tractor moves slightly, pull the control handle of the front drive axle upward in time to make the 2-wheeled drive become the 4-wheeled drive.

### Disconnection of Front Drive Axle

When the front drive axle needs to be disconnected, step on the clutch pedal. Push the control handle of the front drive axle downward to separate the front drive axle.

**Important:** When the tractors perform the general transportation operation on the hard road surface, the joining of the front drive axle is not allowed. Otherwise, the early abrasion of the front wheel will be caused, and the fuel consumption will be increased. The front drive axle can be connected only when the road surface is relatively slippery and the rear wheel is easy to slip after climbing to a large slope in the rainy and snowy days. After the tractor leaves the difficult sections, the front drive axle shall be separated.

## 3.9 Braking the tractor

### 3.9.1 Braking the tractor

- Under normal circumstances, reduce the accelerator first, and then step on the clutch pedal. Then step on the brake pedal gradually according to the situation to stop the tractor steadily.

- During the emergency stop, the clutch and the brake pedal shall be stepped on at the same time. The brake pedal shall not be stepped on alone in order to prevent the rapid abrasion of the friction plate of brake or the stalling of the engine.
- During the braking of the additional trailer, the length of the hanging rod of the brake valve shall be adjusted. The trailer shall be braked first, and then the main engine.



**Warnings:**

1. Every time before dispatching the tractor, the brake shall be ensured to work normally. Otherwise, the major accidents, such as brake failure, will be caused;
2. When the tractor is running on the road, the left and right brake pedals must be interlocked together in order to avoid the side-slipping of the tractor, even the casualties caused by overturn accident during the braking.

### 3.10 Stopping the tractor and turning off engine

- Reduce the accelerator, and reduce the running speed of the tractor.
- Step on the clutch pedal. Then step on the brake pedal. When the tractor is stopped, set the gear shift lever of the gear box in the neutral position.
- Release the clutch and the brake pedal. Reduce the accelerator to make the engine run at idle speed.
- It is pull-rod type to stop the engine.

### 3.11 Use and disassembly & assembly of tire

#### 3.11.1 Use of tire

- The tire is an important part of the tractor. The use and maintenance of the tire must be noted to prolong the service life of it as much as possible.
- All the tires have specified load values. Overload will deform the tire. The sidewall will bend excessively, which is easy to break. The fabrics of the tire body as well as the cushion layer are also easy to degum. The fabric layer becomes loose until the rupture of the tire. Especially when the road surface is uneven or impacted by the obstacles, the tire is easier to break.
- The inflation pressure of the tire must conform to the specifications. The service life will be affected when the pressure is too high or too low. If the air pressure is too low, the tire will have excessive deformation, and the abrasion on the tire surface will be accelerated. Even the inner and outer tires will be damaged rapidly. The inflating valve will be cut off; the driving resistance will be increased at the same time. If the air pressure of the front tire is too low, the operation will be difficult; if it is too high, the fabrics of the tire body will have excessive stretching and then break. The abrasion on the tire surface will be accelerated. The vibration of the body will be increased. During the operation in the field, the air pressure of the tire shall be lower appropriately; and it shall be higher for long-time road transportation. The air pressure of the tire shall be checked under normal temperature with the barometer to avoid the heat of the tire after operation, which can result in incorrect measurement. The improper driving operation will also cause early abrasion or damage to the tires. During the driving, jumping over the obstacles at a high speed, sudden braking or quick turning shall be avoided. When driving on the broken stone surface, the slippage of the tires shall be avoided to the greatest extent.

- During the use, the tires shall not be contaminated with the chemical corrosive substances, such as oil, acid or alkali. Exposed in the burning sun shall be avoided as much as possible to avoid the ageing and deterioration of the rubber.
- The positioning and toe-in of the front wheel must often be checked whether they are correct, so as to avoid the eccentric wear of the tires. When the abrasion of the patterns on the tires is uneven, the left and right tires can be exchanged for use.

**Important:** The inflation pressure of the front and rear tires of the 4-wheeled tractors shall be the same to prevent the abnormal abrasion of the tires.

### 3.11.2 Disassembly & Assembly of tire

#### Disassembly of tire

Special tools shall be used during the disassembly and assembly of the tires. Hard and sharp tools (such as the screwdriver) and sledge hammer are forbidden to be used to beat or knock randomly in order to avoid the puncturing of the tires or the damage of bead or rim.

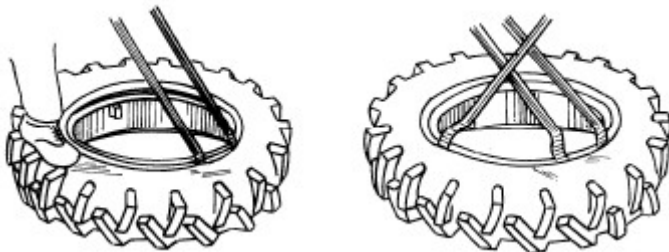

Figure 3.11.2 Disassembly of tire

During the disassembly of the tires, the air shall be released first. The bead on

both sides of the outer tire shall be pressed to the groove of the rim. Then lever the bead of one side from the vicinity of the inflating valve off the rim with the crowbar. Then lever the whole bead off with two crowbars alternatively. After taking out the inner tire, lever the bead of the other side off with the same method. Remove the outer tire.

#### Assembly of tire

During the installation, after all the parts are wiped clean, coat a thin layer of talc powder between the inner and outer tires;

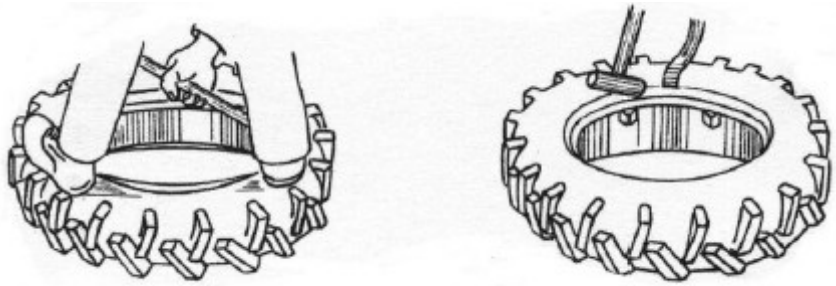

Figure 3.11.2-1 Assembly of tire

Lay the rim flat. Install the outer tire by foot or lever it into the rim with the crowbar. Put the inner tire (the outer tire can be raised slightly). Fix the inflating

valve to the valve hole of the rim with lead wires to prevent the slippage;

Lever the other side of the outer tire into the rim (It is most strenuous at the last section. The hand hammer can be used to tap the crowbar lightly);

Finally, check whether the position of the inflating valve is crooked, and whether the flange and the rim are jointed closely;

During the inflation, recheck whether the inner tire is damaged. Tap the outer tire with a hand hammer during the inflation. It is better to release half of the gas when inflated to the specified air pressure, and then inflate again to make the inner tire expand normally and eliminate the crimping phenomenon.



**Warning:** It is forbidden to disassemble the bolts connecting the tire, driving hub and rim in the inflation state. Otherwise, the bolts may fly out to hurt people.

### 3.12 Use of counterweight

The use of counterweight shall be increased or reduced according to the use requirements of the tractor.

During the field operation on the dry land and the transportation operation, when the traction force needs to be increased, the counterweight shall be added; when the tractors are used in the mountainous areas or the hilly areas, the front counterweight shall be added appropriately to avoid the “lifting of head” phenomenon during the operation.

The rear counterweight is the disk-type iron casting. The mass of each piece is 31kg. Two pieces can be installed respectively at the left and the right. The total mass of the rear counterweight is 124kg. The mass of each piece of the front counterweight is 9kg. 6 pieces can be installed. The total mass of the front counterweight is 54kg.

**Note:** Before the rear wheel with rear counterweight is removed from the tractor, the rear counterweight shall be removed from the tire first to avoid the casualty accidents caused by instability.

### 3.13 Adjustment of drivers seat

1. The longitudinal position of the driver seat of the AK Series Tractors can be adjusted. During the adjustment, wrench the adjustment handle A at the left bottom of the driver seat outwards (as shown in Figure 3-13 below). At the same time, move the driver seat forward or backward. When the required position is reached, release the adjustment handle.
2. Adjust rigidity adjusting handle B, according to driver's height and weight, to make driver more comfortable.
3. According to the height of driver, adjust height adjusting handle C to make driver more comfortable.

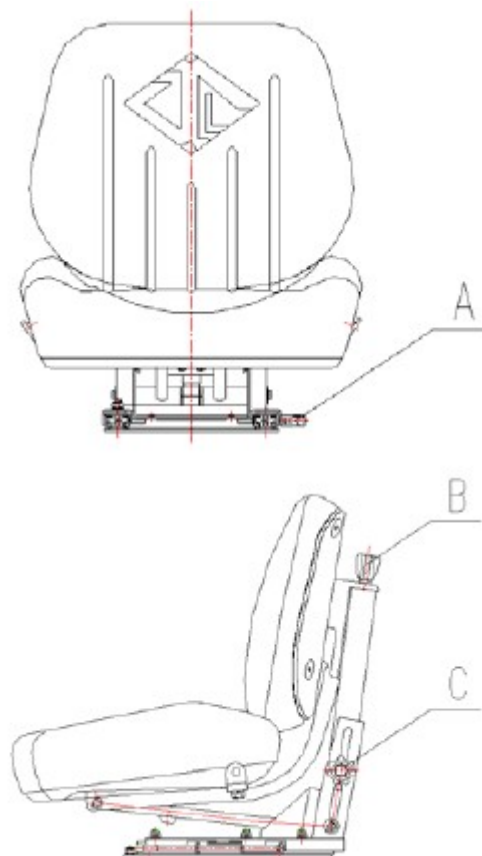

Figure 3-13 - Adjustment of drivers seat



**Note:** For safety's sake, the adjustment of the seat must be carried out when the tractor is safely parked and not during operation.

### **3.14 Outer parts of the tractor**

Outer parts of tractor main include hood, ROPS, mud guard, instrument panel, floor, accessories and so on.

#### **3.14.1 Hood**

The engine hood of the tractor adopts beautiful streamline metal plate structure. Pull the hood lock opening handle which is on the left of hood lower hoardings to open the hood lock. Then the hood opens automatically driven by the gas spring. Pull the hood downward, the hood lock will lock automatically when the hood falls to a certain level.

#### **3.14.2 Instrument panel**

The electric control switch and combined instrument of the tractor are installed on the instrument panel. The instrument panel plays the role of control switch support, decoration and sealing.

#### **3.14.3 ROPS (Roll over protection system)**

The tractor ROPS is the frame which is welded by rectangular tubules. ROPS can flip folded backwards.

The tractor can be equipped mid-mounted ROPS. The ROPS can slip folded forward.

### **3.15 Use of Working Devices of Tractor**

The AK Series Tractors adopt the half-split hydraulic lifting system, with two adjustment modes, i.e. position adjustment and height adjustment. The raising and falling of the farm implements are realised through the control handle of the control distributor. The farm implements will fall when the handle is pressed forward; the farm implements will rise when the handle is pulled backwards. See "Adjustment of Hydraulic Lifting System" for the adjustment of the maximum raising position and the minimum falling position of the farm implements.

### 3.15.1 Position Adjustment

When the tractor connected to the farm implement without earth wheel is used for farming, the position adjustment shall be adopted. The tilling depth of the farm implements is determined by the position of the falling block on the returning push rod. When it is used, the falling block shall be fixed to the pre-selected proper position. When the farm implements fall to the required tilling depth and the gear pin hits the falling block, push the handle back to the neutral position, and then the farm implements stop falling and will work under this tilling depth (see “Adjustment of Hydraulic Lifting System” for the adjustment method).

### 3.15.2 Height Adjustment

When the tractor connected to the farm implement with earth wheel is used for farming, the height adjustment shall be adopted. The tilling depth of the farm implement is controlled through the adjustment of the height from the earth wheel to the plow bottom. When it is used, adjust the falling block to the minimum falling position. When the farm implements fall to the required tilling depth, the handle is still in the falling position (see “Adjustment of Hydraulic Lifting System” for the adjustment method). The farm implements will work under this tilling depth.

**Note:** During the use, the positions of the two returning blocks on the push rod shall be adjusted according to the agricultural requirements and the equipped farm implements. If the positions of the blocks are different on the push rod, then the raising and falling heights of the farm implements will also be different. The raising block and the falling block control the raising and falling heights of the farm implements respectively.

### 3.15.3 Adjustment of Falling speed

The adjustment of the falling speed can control the falling speed of the farm implements. The selection of appropriate falling speed of farm implements can prevent the damage to the farm implements caused by the severe impact during the contact of the farm implements with the ground. Before each tractor leaves the factory, the falling speed regulating valve has already been adjusted well preliminary. The driver can readjust it according to the weight of the farm implements in use as well as the hardness of the ground during the use of the tractor.

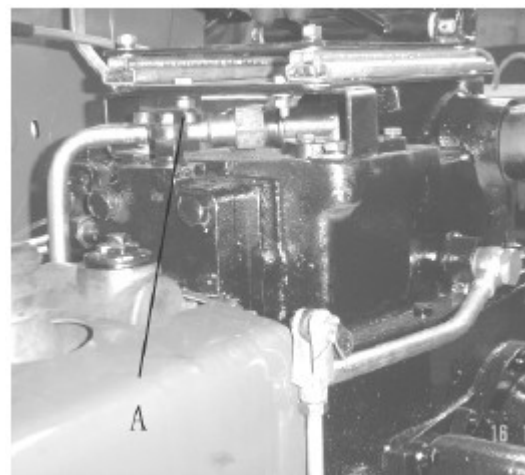

Figure 3-15 - Regulator valve

- Rotate the regulating valve A clockwise, and then the falling speed of the farm implements will slow down;
- Rotate the regulating valve A counterclockwise, and then the falling speed of the farm implements will speed up. (as shown in Figure 3-15)

### 3.15.4 Hydraulic Output and Use of Hydraulic Lock

- Rotate the falling speed regulating valve B clockwise until the valve is tightened to the greatest extent (at this time, the oil inlet and outlet of the oil cylinder are closed by the regulating valve). Connect the male connector of the quick connector to the hydraulic fluid port of the farm implements. Connect the hydraulic output female connector A to the male connector of the farm implements. Then wrench the control handle of the distributor to the raising position to realise the hydraulic output. The simple hydraulic output only can control the single-acting oil cylinder.

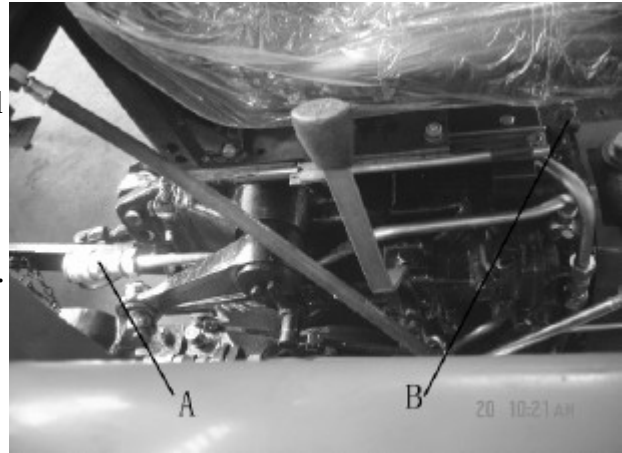

Figure 3-16 - Hydraulic output

- During the use of hydraulic output, when the farm implements are in the raising position, if the falling speed regulating valve B is tightened to the greatest extent to make the oil cylinder cannot return the oil, and the farm implements are locked to the transportation position, then the regulating valve acts as the hydraulic lock.



**Note:** When the tractor hanging farm implements runs for a long distance, the hydraulic lock shall be used to lock the farm implements in order to prevent the touch to the control handle of the distributor during the running of the tractor, which will make the farm implements fall suddenly and cause accidents.

### 3.15.5 Use of Multiple Unit Valve (optional)

- Shut down the engine.
- Put the lifter to the falling position.
- Move the control handle of the hydraulic output valve forward and backward to eliminate the pressure in the hydraulic quick connector plinth.
- Remove the sealing cover of the quick connector plinth. Clean the quick connector.
- Connect the spare male connector (it is placed in the spare part case) with the female connector of the quick connector. Then connect it to the oil inlet and outlet of the double-acting oil cylinder of the farm implements. The multiple unit valve has four female connectors of quick connector, i.e.

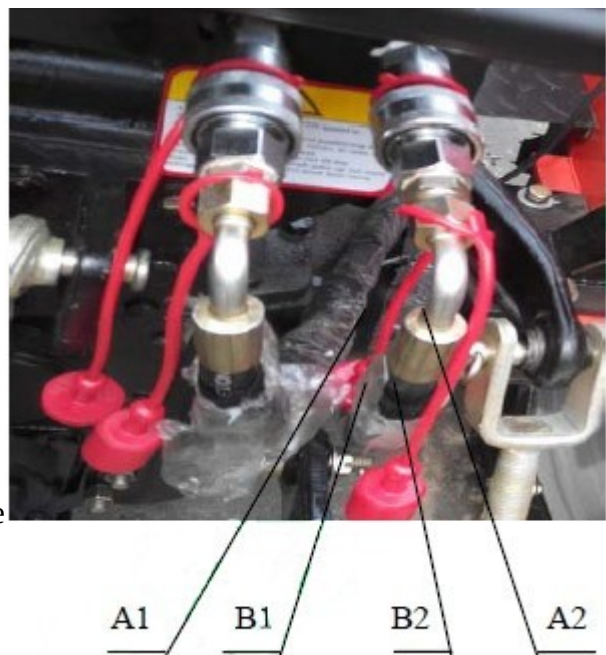

A1, B1 and A2, B2. A1 and B1 form the first group of hydraulic output loop. A2 and B2 form the second group of hydraulic output loop.

**Important:**

1. When the hydraulic output device is not used, the connector plinth shall be covered with sealing cover to avoid the entering of dust.
2. After the operation of the hydraulic output device, the control handle shall be set in the neutral position. Otherwise, overheat of the hydraulic system will be caused.

### 3.15.6 Use of Hitch

During the ploughing operation, in order to keep the tilling depth of all the ploughshares consistent from beginning to end, the longitudinal and horizontal level adjustment shall be carried out for the plough.

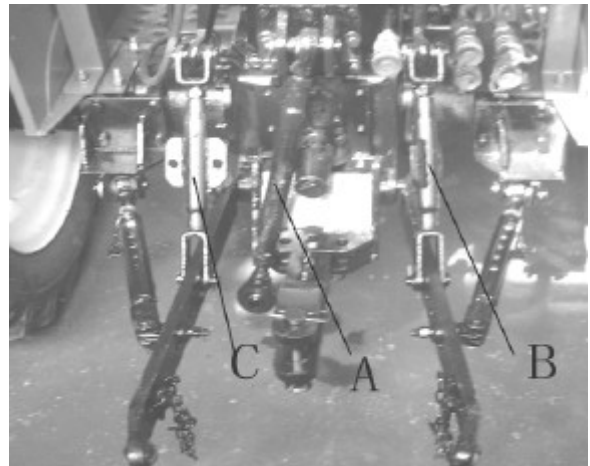

- Longitudinal level adjustment: Adjust the length of the upper tie rod A to make the plough stock keep level in the longitudinal direction, so as to make the tilling depth of all the ploughshares consistent. When the front ploughshare is deep and the rear ploughshare is shallow or the heel leaves the trench bottom, the upper tie rod shall be stretched; when the front ploughshare is shallow and the rear ploughshare is deep or the heel compacts the trench bottom, the upper tie rod shall be shortened.
- Horizontal level adjustment: Adjust the length of the left and right lifting rods to make the plough stock keep level in the horizontal direction. If the right lifting rod B is stretched, the tilling depth of the first ploughshare will increase; if the right lifting rod is shortened, the tilling depth of the first ploughshare will become shallow. In general, the left lifting rod C shall not be adjusted. The left lifting rod is adjusted only when the adjustment of the right lifting rod is not enough, so as to make the tilling depth of all ploughshares be consistent.

**Important:**

1. During the ploughing, it is forbidden to adjust the deflective traction of the farm implements by using the method of fixing the limited rod, so as to avoid the damage to the hitch;
2. During the ploughing with the tractor, it is forbidden to change direction when the farm implements are not lifted, so as to avoid the damage to the hitch. The change of direction can be operated only after the ploughshares are unearthed.

**Notes:** The limited rod is mainly used to prevent the impact on the rear wheel of the tractor caused by the overlarge swing of the lower tie rod when the tractor turns around lifting the farm implements at the field edge. When the farm implements are in the ploughing position, the limited rod is in a loose state. Therefore, a certain amount of swing between the tractor and the farm implements is allowed.

### 3.15.7 Operation of draw and clevis coupling device

#### 3.15.7.1 Drawbar

Drawbar can only be used in drawing implement. The back-end of drawbar connects with the implement through drawing pin. Drawbar can sway transverse, so it is easy to hang the implement. Drawbar can sway left and right when the tractor is working. But when the tractor is reversing with drawing implement, two location pins should insert into the holes of drawing plate to make drawbar not sway. The height of drawbar point can change by turning drawbar to match the implement.

#### 3.15.7.2 Clevis device operation

Adjustable clevis device has upper and lower working positions.

- When only uses clevis device, people can choose upper position or lower position according to the implement.
- When the tractor matches implement which is using power output shaft, it is better to choose lower working position.
- The clevis device should be in upper working position when it leaves the factory (refer to figure 3-19). Drawing pin and support sleeve should assemble together with spring lock pin, and then put in spare parts box.
- Choose suitable connecting position to connect trailer hook and tractor U-shape hook, and then use clevis pin to connect.

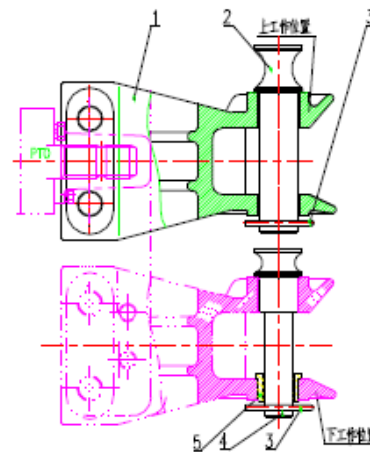
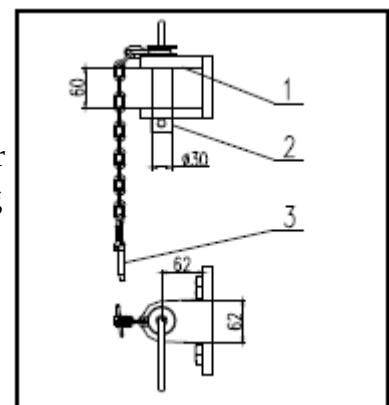

Figure 3-19 Operation of clevis device  
1. clevis 2. clevis pin  
3. spring lock pin 4. drawbar pin  
5. support sleeve

Clevis is useful of all kinds of trailers. But it can not install with drawbar at the same time.

#### 3.15.7.3 Front coupling device

When there are some malfunctions in the tractor which can not run properly, the tractor can be connected to the towed vehicle by rope or towing device. Before the tractor in malfunction is towed, the towing pin is locked tightly.



**Warnings:**

1. Never overload while drawing and with trailer. Otherwise, it will reduce the machine lifetime. And it will cause the tractor destroy and the person die when it is seriously.
2. While braking, the braking of the trailer should be a little earlier than that of the tractor to avoid rollover.

### 3.15.8 Dimension drawing of Hitch System (mm)

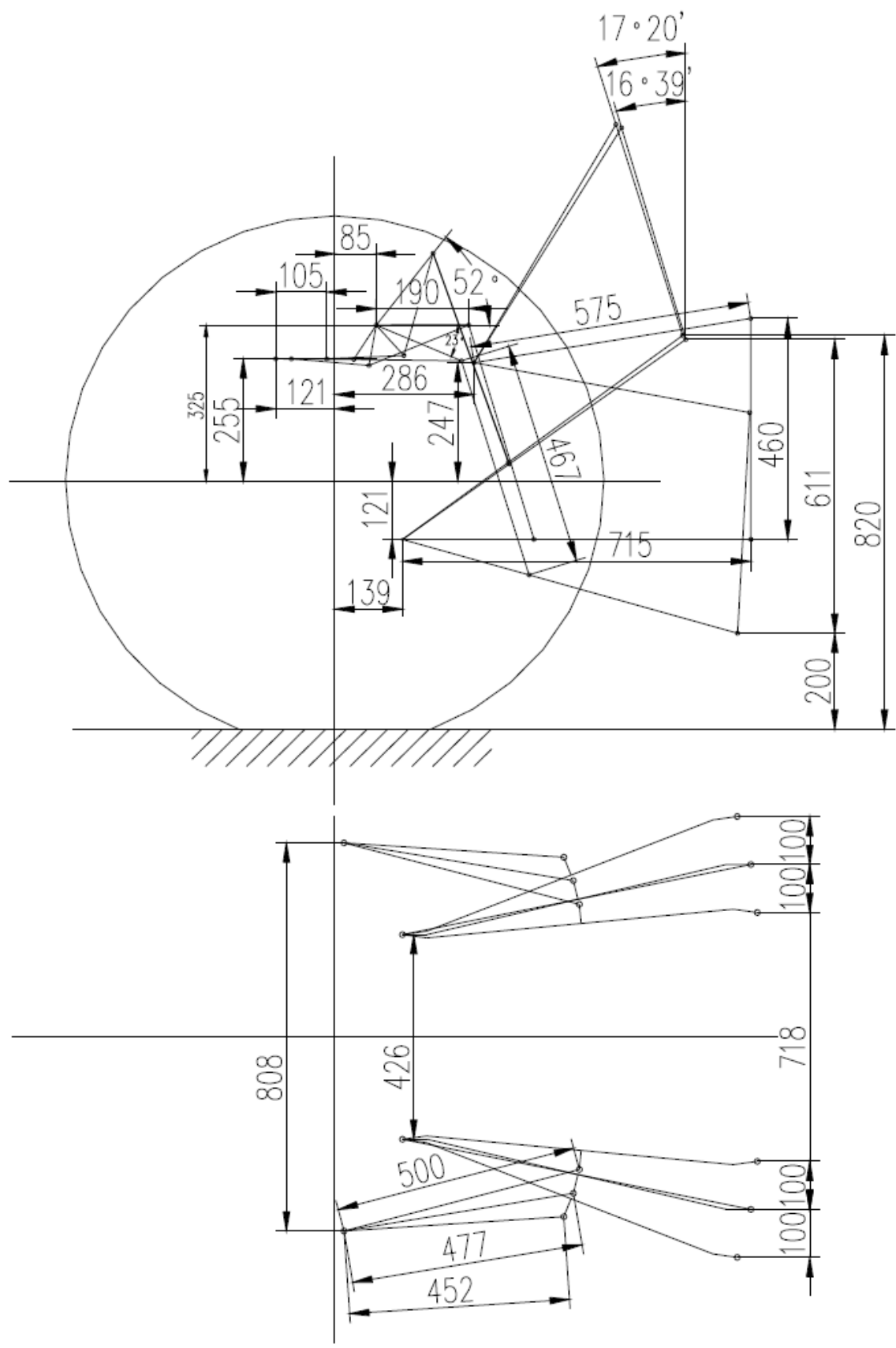

### **3.15.8.1 Use of Power Take off Shaft (PTO)**

The connection and disconnection of the power of the power take off shaft are achieved by manipulating the double-acting clutch and the power take off gear shift handle. When the power take off gear shift handle is turned forwards, it will be the high gear; turn the handle backwards, and then it will be the low gear. The use method is as follows:

- Remove the trailing device and the protective cover of the power take off shaft, and install the required supporting farm implements;
- Put the power take off gear shift handle in the required gear;
- Step on the clutch pedal to the floor to disconnect the power take off clutch. Then turn the power take off disconnection control handle to the “connected” position;
- Release the clutch pedal slowly. First operate with the up position of the accelerator in a low speed to check whether the operation is normal, then start working;
- When the repeated work in a fixed place within a short time is required, step on the clutch pedal gently to disconnect the main clutch. Then the power of the tractor transmission box is cut off, and the tractor stays in its place while the farm implement behind it can still work normally;
- After connecting the power take off unit, reinstall the protective cover of the power take off shaft.

### **3.15.9 Use of Electrical Equipment**

The electrical system of AK Series tractors is the type of 12V negative double bond straps. See figure below for composition and wiring of electrical system.

#### **3.15.9.1 Battery / Accumulator**

The battery is used to store the electrical energy generated by the generator, which can supply the stored energy to the electrical equipment of the tractor when the generator is not working or running in a low speed, and can help with power supply when the generator is overloaded in a short time.

- Frequently remove the dust and mud on the battery shell to avoid electric leakage. Check whether there are cracks and leakage of electrical liquid. Ensure good contact between the terminal and the conducting wire. The air vent of the plastic cover should not be blocked in order to avoid explosion;
- Frequently check the voltage of the battery, and charge it promptly if the voltage is over-low.
- The starting time should not exceed 15s each time to avoid excessive discharging;
- If the tractor is not used for a long time, the battery should be taken off for charging and maintenance.



### **3.15.9.2 Generator**

The generator must be used with a matched regulator;

1. The silicon rectification generator is minus “—” grounded; the connection of the positive and negative poles of the generator, the regulator and the accumulator should be correct to avoid burnout of the generator and the regulator;
2. The method of grounding and making sparks is strictly forbidden for checking whether the generator is generating electricity;
3. Pull out the key of the ignition lock when the tractor stops to cut off the connection between the motor and the accumulator to prevent the accumulator from discharging for an extended time.

### **3.15.9.3 Starter**

- The starter should not run in an extended period. The starting time should not exceed 5s each time to avoid damage to the starter;
- If clear impact sound (teeth collision) of the small gear of the starter and the flywheel ring gear is heard at the moment of starting, make the key back to its position immediately and make the second starting;
- If the starter still continues running after the key is back to its position during starting, stop the engine immediately and start again after the faults are eliminated.

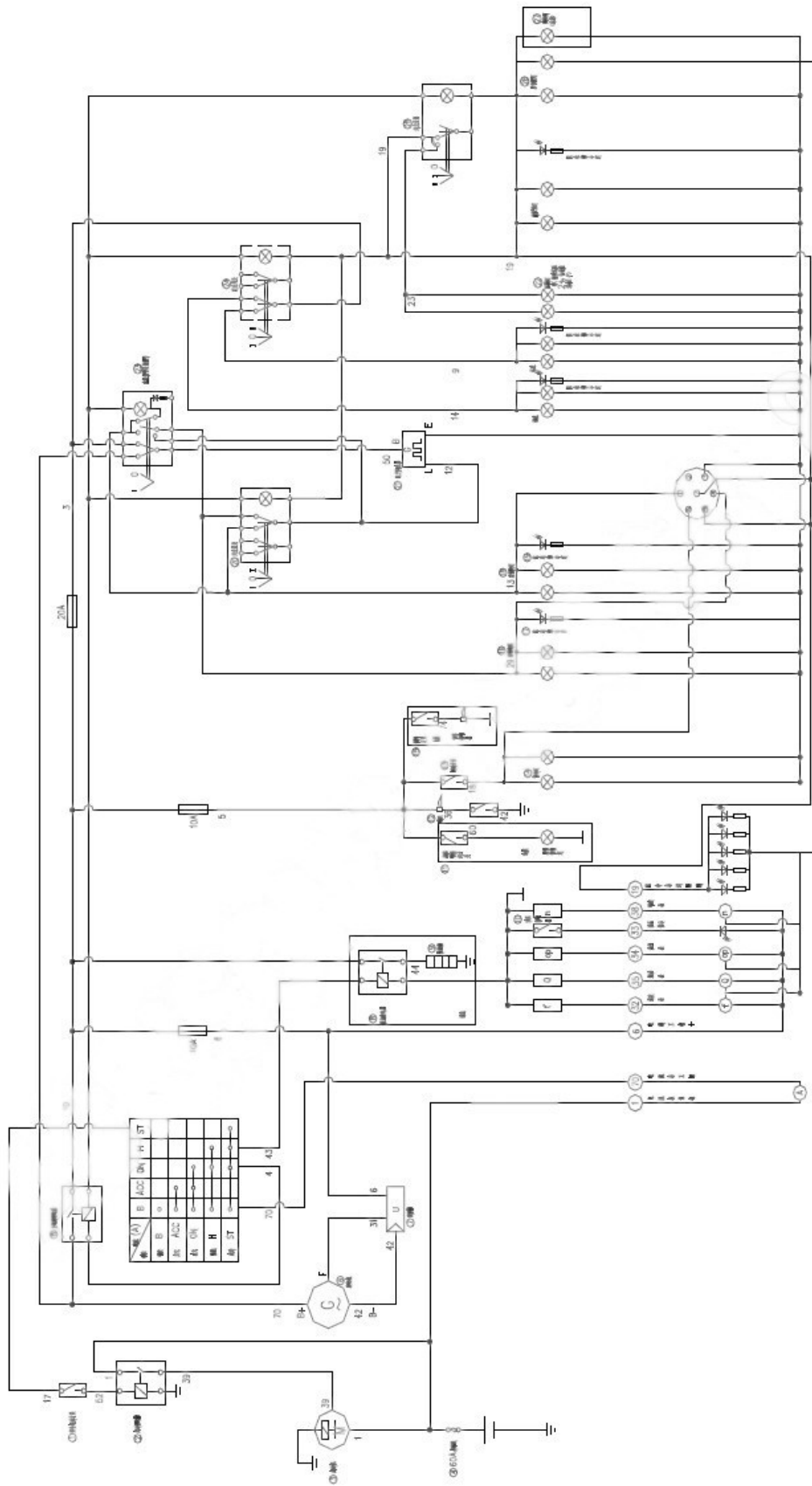

Figure 3-29 Electrical wiring system

### **3.16 Running in of tractor**

Before the tractor is put into service, it should run for a certain period under the specified conditions of lubrication, rotational speed and load, and at the same time be treated with necessary inspection, adjustment and maintenance, to normalise its technical state, which process is called running-in.

#### **3.16.1 Preparations before running in**

- Implement technical maintenance per shift and 50h technical maintenance for the tractor during the running in (See '4 Maintenance Instructions' in this instruction manual).
- Check and tighten the outer bolts, nuts and screws of the tractor.
- Add grease to the grease cups of the front wheel hub, the kingpin of the front drive axle and the water pump shaft. Check the oil level of the engine oil pan, the transmission mechanism and lifter, the central drive and final drive of the front drive axle. Add oil according to the specifications if insufficient.
- Fill them with adequate fuel and coolant corresponding to the grade.
- Check whether the tire pressure is normal.
- Check whether the electrical wiring is connected correctly and reliably.
- Put all control handles in the neutral gear.

#### **3.16.2 Idle running in of Engine**

Implement a 15min idle running in for the engine. After starting the engine in the sequence specified in the 'Instruction Manual for the Use and Maintenance of Diesel Engine', make the engine run in three stages in sequence, i.e. low speed (the up position of the accelerator), then medium speed (the medium position of the accelerator) and finally high speed (the down position of the accelerator), each for 5 minutes.

During the idle running in of the engine, check the working state of the engine, the air compressor and the hydraulic oil pump carefully to observe whether there is abnormal occurrences and sounds as well as the leakage of water, oil and air. Check whether the instruments are working normally. If any abnormalities are found, immediately stop the tractor to eliminate the faults, and then continue the running in.

The following running ins should not be implemented unless the engine is ensured to work normally.

#### **3.16.3 Idle running in of Power Take off Shaft**

Put the accelerator control handle in the position of accelerator medium position, and let the engine run with medium speed. Let the power take off shaft run 5min separately in low and high speed and check abnormalities. After running in, the power take off shaft should be in the position of neutral gear.

### **3.16.4 Running in of Hydraulic System**

Start the engine and put the accelerator in the medium position for operation. Manipulate the distributor handle and make the hitch rise and drop for several times to check abnormalities. Then hang a load of 300kg or the matched farm implement with an equivalent mass on the hitch to make the engine run in the down position of the accelerator. Manipulate the distributor handle to make the hitch rise and drop in total stroke for equal to or more than 20 times. Check whether the hydraulic hitch can be fixed in the highest or required position.

Check the time of rise and drop and leakage.

With the tractor static, make the engine run in low, medium and high speed, and manipulate the steering wheel steadily to the left and to the right for 10 times separately. Watch the following of the left and right turning of the tractor. Check whether the sound is normal and the manipulation of the steering wheel is easy and steady.

If any faults are found during the running in, find out the causes promptly and eliminate them.

### **3.16.5 Idle and Loaded Running in of Tractor**

After the idle running in of the engine and the running in of the power take off shaft and hydraulic system, confirm that the technical state of the tractor is absolutely normal before implementing the running in of the whole tractor according to Table 3-2, 3-3. The total running in time is 50h. During idle running in, make turns in a low speed and use the one-side brake properly. Also test emergency brake in a high speed.

After idle running in, loaded running in can be implemented only if the technical state of the tractor is absolutely normal. This process should be carried out with the load from light to heavy and the gear from low to high and one after another. During the running in, note that:

- Whether the readings of electrical equipment and various instruments are normal.
- Whether the engine is running normally.
- Whether the connection of the clutch is smooth and the disconnection is complete.
- Whether the gear shift of the gear box is easy and flexible, free of gear confusing and automatic off-gear.
- Whether the brake works reliably.
- Whether the connection and disconnection of the differential lock are reliable.
- Whether the connection and disconnection of the front drive axle are reliable.
- If faults are found, eliminate them before continuing the running in.

### **3.16.6 Technical maintenance after running in**

After the running in of the tractor, there will be some metal dust or dirt mixed in the grease in the transmission, lubrication systems and the hydraulic system. Therefore, all lubricating oil and oil for the hydraulic system should be cleaned and replaced. Implement necessary technical maintenance for the tractor before putting it into normal use. Technical maintenance after running in includes:

- After the engine stops, discharge the engine oil in the engine oil pan and the steering mechanism oil tank before it cools down, and clean the filter screens in the oil pan, the engine oil filter screen, the diesel filter, the engine oil filter, the air filter and the steering oil tank. Add new lubricating oil according to the technical requirements after the filter elements of the diesel filter and the engine oil filter are replaced.
- Discharge the oil liquid in the transmission mechanism, the lifter and the front drive axle before it cools down, and add proper amount of light diesel or kerosene. With the engine not started, haul the tractor forwards or backwards in a low speed for around 3min, or lift the front and rear tires of the tractor away from the ground and turn them in two directions for around 3min and immediately discharge the cleaning liquid. Also remove the oil absorption filter of the lifter for cleaning. After reinstalling it, add new oil liquid to the lifter of the transmission mechanism and the front drive axle according to the specifications.
- Carry out the technical maintenance for the diesel engine according to the specifications of the 'Instruction Manual for the Use and Maintenance of Diesel Engine'.
- Discharge the cooling water and clean the engine cooling system with clean water, then add new coolant.
- Check the free paths of the toe-in of the front wheel, the clutch and the brake. Adjust them if necessary.
- Check and tighten all outer bolts, nuts and screws.
- Add grease to each part of the tractor according to the maintenance table.

**Important:**

1. The tractors that have just left the factory or are overhauled should be run in before put into normal service, otherwise, their service lives will reduce.
2. The drivers should first learn and master the manipulation and use of the tractors before carrying out running in for the tractors.

## Running in time of various phases (Unit: h)

Tractor Gear	Forward Gears								Reverse gears							
	Low 1	Low 2	Low 3	Low 4	High 1	High 2	High 3	High 4	Low 1	Low 2	Low 3	Low 4	High 1	High 2	High 3	High 4
Idle	0.5	0.5	0.5	0.5	0.5	0.5	0.5	0.5	0.5	0.5	0.5	0.5	0.5	0.5	0.5	0.5
Loaded with 3t weight with Trailer , Road Transportation				4	4.5	5	5	2.5								
Operating on Sand Soil with Plow, Tilling Depth 14cm		5	5	5	5	4										

## 3.17 Common Faults and Solutions

### 3.17.1 Troubleshooting of Chassis

#### 3.17.1.1 Troubleshooting of clutch

Problem	Possible Cause	Remedy
The clutch slips	The friction plate and pressure plate have greasy dirt.	Clean with gasoline. Find out the causes and eliminate the fault
	The friction plate is excessively worn or burnt.	Replace the friction plate.
	The spring pressure decreases	Replace the spring
	The free path of the pedal is too small or there is no free path	Re-adjust the free path of the pedal according to the specifications
The clutch does not disengage completely. Sound is heard when engaging the gear	The clutch spider has badly deformed	Replace the clutch spider
	The free path of the pedal is too great and the working path is too small	Adjust the free path of the pedal according to the specifications
The tractor shakes when starting	The clutch spider has excessively warped	Replace the clutch spider
	The heads of the three disengaging levers are not in the same plane	Make adjustment according to requirements
	The heads of the three disengaging levers are not in the same plane	Make adjustment according to requirements
	The friction plate and the clutch spider have grease on them	Clean the friction plate and the clutch spider

The clutch spider has badly warped	Replace the clutch spider
The fastening screw for the flywheel and the clutch has loosened	Stop the tractor immediately to make inspection and eliminate the fault

### 3.17.1.2 Troubleshooting of gearbox

Problem	Possible cause	Remedy
It is difficult or unable to engage the gear	The clutch has disengaged incompletely	Make elimination according to the clutch fault solutions
	The gearshift interlocking rod is too long	Properly shorten the gearshift interlocking rod
	The shifting block of the gear lever is severely worn	Replace the gear lever
	The end face of the engagement sleeve or that of the gear is worn or broken	Make replacement or repair
Automatic off-gear	The gearshift interlocking rod is too short	Properly lengthen the gearshift interlocking rod
	The locating slot of the shifting fork shaft is severely worn	Replace the shifting fork shaft
	The spring pressure of the interlocking latch is insufficient	Adjust or replace the spring of the interlocking latch
	The bearing on the gear shaft is worn, making the shaft tilt	Replace the bearing
Gears are confused	The spline of the tooth holder is worn	Replace the tooth holder
	The shifting block of the gear lever is worn	Repair or replace the gear lever
	The gear guide plate is severely worn	Replace shift gear guide plate
	The shifting slot of the shifting fork and the engagement sleeve are worn	Replace the shifting fork and the engagement sleeve
Noise or impact sound can be heard in the gear box	The locating slots of the interlocking latch and the shifting fork shaft are worn	Replace the interlocking latch and the shifting fork shaft
	The gear is excessively worn and the tooth surface has chipped off	Replace the gear
	The bearing is badly worn or damaged	Replace the bearing.
	The lubricating oil is insufficient or oil quality does not conform to the specifications	Add sufficient lubricating oil or replace it

### 3.17.1.3 Troubleshooting of rear axle and brake

Problem	Possible Cause	Remedy
The noise of the central drive increases	The windage of the bevel pinion bearing is too great	Make adjustment according to requirements
	The gear has engaged abnormally	Make readjustment according to requirements
	The bearing or gear of the bevel gear pair is damaged	Replace the bearing or the gear
	The differential shaft is worn or locked	Replace the differential shaft
	The planet gear or the shim is worn	Replace the planet gear or the shim
	The differential bearing is worn or damaged.	Replace the differential bearing
The bevel pinion shaft and the differential bearing are overheated	The pre-tightened force is too great	Readjust the pre-tightened force of the bearing
	Bad lubrication	Check the lubricating oil level and make supplementation if insufficient
	The gear backlash of the bevel gear pair is too small	Readjust the gear backlash
The final drive makes an abnormal sound.	The bearing, gear or shaft is damaged	Replace the bearing, gear or shaft
Brake fails	The free path of the brake pedal is too great.	Readjust the free path of the pedal
	The friction plate is severely worn or eccentrically worn	Replace the friction plate
	The free path of the pedal is too great	Adjust the free path of the pedal according to the specifications
The brake heats	The friction plate of the brake does not return.	Replace the return spring
	The friction plate does not completely disengage from the brake drum	Make adjustment according to requirements
The tractor goes askew when braking	The free paths of the left and right brake pedals are not the same	Make adjustment
	The brake friction plate of one side is damaged	Replace the friction plate
	The air pressure of the two rear tires is not the same	Check and inflate the tires according to the specifications



### 3.17.1.4 Troubleshooting the running system

Problem	Possible cause	Remedy
The front tire is severely worn	The rim or the radial plate of the front wheel has severely deformed	Align the front wheel rim or the radial plate
	The toe-in has been improperly adjusted	Adjust the toe-in
	The bearing pins of the steering knuckle and the oil cylinder are severely worn	Replace the bearing pin
	The tire pressure is insufficient during transport operation	Inflate the tires according to the specifications
	The front drive axle does not disengage during transport operation	Disengage the front drive axle
	The direction of the tread of the front drive tire is inverted	Reinstall the tire according to requirements
The front wheel swings	The fastening nuts and bolts for the ball stud, the oil cylinder and the steering swing arm have loosened	Check and fasten
	The toe-in has been improperly adjusted	Adjust the toe-in
	The clearance of the bearing is too great, or the bearing is severely worn	Adjust or replace the bearing
	The rim of the front wheel has severely deformed	Align the front wheel rim
Noise is loud	The engagement imprint of the central drive gear is bad	Readjust the engagement imprint
	The clearance of the central drive bearing is too great or the bearing is damaged	Make adjustment or replacement
	The differential shaft is worn or damaged	Replace the differential shaft
	The planet gear or the shim is worn	Replace the planet gear or the shim
	The engagement of the final planet gear pair is bad.	Replace the planet drive gear
The jacket of the transmission shaft heats	The transmission shaft is severely bent	Align or replace the transmission shaft
	Friction occurs	
The noise of the transfer case is loud	The speed gear is too high	Engage the low gear
	The bearing or the gear is badly worn	Make replacement or repair

### 3.17.1.5 Troubleshooting of hydraulic steering system

Problem	Possible Cause	Remedy
Oil leakage	The rubber ring at the joint of all pipelines is damaged or the bolt has loosened	Replace the rubber ring or tighten the bolt
	The rubber ring at the joint surface of the hydraulic steering rack valve block, the stator and the back cover is damaged	Clean or replace the rubber ring
	The rubber ring at the axle journal is damaged	Replace the rubber ring
	The bolt at the joint of the steering rack has loosened	Tighten the bolt
Steering is heavy	The oil supply of the geared oil pump is insufficient, or the geared oil pump leaks inside or the filter screen in the steering oil tank is blocked. It is light with slow turn and heavy with fast turn	Check whether the geared oil pump is normal and clean the filter screen
	The oil cylinder does not necessarily move when turning the steering wheel	Discharge the air in the system and check whether there is any intake of air in the oil suction pipeline
	The spring elasticity of the safety valve has weakened, or the steel ball is not sealed. It is light with a light load and is heavy with the increase of the load	Clean the safety valve and adjust its spring pressure
	The viscosity of oil liquid is too great	Used the specified oil liquid
	The steel ball one-way valve in the valve body has failed. Quick and slow turns of the steering wheel are all heavy and the steering is weak	Maintain or replace parts
Steering fails	The shifting pin is broken or deformed	Replace the shifting pin
	The opening of the universal driving shaft is broken or deformed	Replace the universal driving shaft
	The relative position of the rotor and the universal driving shaft is wrong	Reassemble them
	The piston of the steering cylinder or the seal ring is damaged.	Replace the piston or the seal ring
No manual steering	The clearance between the rotor and the stator is too great	Replace the rotor and the stator
	During power steering, the driver's	Replace the seal ring of the

	sense of the end is not apparent when the cylinder piston is in the extreme position; during manual steering, the steering wheel turns but the oil cylinder does not act.	piston
Steering is not quickly responded	The clearance between the valve core and the valve housing is too great	Make replacement
	The clearance between the universal driving shaft and the shifting pin is too great	Make replacement
	The clearance between the universal driving shaft and the rotor is too great	Make replacement
	The return spring is broken or too flexible	Make replacement

### 3.17.1.6 Troubleshooting the hydraulic hitch system

Problem	Possible cause	Remedy
Both light load and heavy load cannot be lifted.	The oil level within the lifter shell is too low.	Fill oil to the specified oil level.
	Blockage at the filter screen of oil filter is serious.	Clean or replace the filter screen of oil filter.
	Air intake of oil suction pipeline	Check the pipeline connections
	Failure of geared oil pump	Check and repair or replace the geared oil pump.
	Falling off of the spring pin at the outer end or inner end of the control handle shaft	Reinstall the spring pin
	Falling off of the swing link in the distributor	Open the distributor, and install the swing link
	Main control valve is clamped and stagnated at the neutral or lowering position, or the oil return valve gets stuck at the open position.	Take apart the distributor, and clean each valve.
	The pin becomes shorter or the lowering valve assembly becomes loose and backs out, which makes the lowering valve unopened.	Take down the lowering valve plug, and readjust the clearance of lowering valve pins or tighten the lowering valve assembly.
	Oil circuit in the cylinder head leading to oil cylinder is closed	Open the oil circuit
Light load can be lifted, and heavy load cannot be lifted or can be lifted slowly.	Inhaling air or air intake of the oil suction pipeline	Check the oil suction pipeline and oil filter
	Adjusting pressure of the system safety valve is too low.	Adjust or replace the system safety valve

	Adjusting pressure of the oil cylinder safety valve is too low.	Adjust or replace the safety valve of oil cylinder
	The abrasion of geared oil pump is serious and the pressure is insufficient.	Repair or replace the geared oil pump. Replace the seal ring of oil cylinder.
	The seal ring of oil cylinder leaks oil.	
Farm implements tremble during the lifting process and are lifted slowly.	Blockage of the oil filter	Clean or replace the filter element
	Air intake of the oil suction pipeline	Remove the air leakage at joints and O-rings
	Failure of the geared oil pump	Replace the geared oil pump
	Hydraulic oil level is too low.	Fill the lubricating oil according to the requirements.
Farm implements “nod” frequently after being lifted, and the hydrostatic settlement becomes fast after stopping of the engine	One-way valve of the distributor is not sealed tightly	Clean the one-way valve, and carry out the lapping-in if necessary
	The lowering valve is not sealed tightly.	Clean or lap in the lowering valve
	The safety valve leaks oil or is not adjusted properly	Repair or readjust the safety valve of oil cylinder.
	The O-ring at the piston of oil cylinder is damaged, which causes the oil leakage.	Replace the O-ring.
	The seal ring between the distributor or cylinder head and the oil inlet hole on the lifter shell is not well installed and falls off or is damaged.	Check and replace the seal ring
When the handle at lifting position, the distributor makes a sharp sound.	The adjustment is not correct, and the internal lift arm hits the lifter shell and makes the safety valve open.	Firstly, measure the lifting height of the farm implement at this time. Then make a readjustment and shorten the force position adjusting lever to make the highest lifting position lower than the original position.
There is no hydraulic output at the cylinder head, or the output is powerless.	The inlet oil line has not been cut off	Clockwise tighten the lowering speed control hand wheel
	The cone and the conical bore of the lowering speed control valve are not sealed tightly.	Carry out the lapping-in repair for the front cone and conical bore of the lowering speed control valve, or replace the lowering speed control valve.

### 3.17.1.7 Troubleshooting of air brake system

Problem	Possible cause	Remedy
Insufficient Air Pressure	Air leakage of the pipeline	Check the air leaking position and exclude it
	The intake or exhaust valve sheet of the air pump is abraded or the spring is damaged.	Replace
	The piston ring of air pump or the cylinder sleeve is seriously abraded	Replace the piston ring and cylinder sleeve
	Failure of the air-pressure alarm	Repair or replace the air-pressure alarm.
	The safety valve is not tightly closed	Check or replace the safety valve.
The air cut-off brake valve does not return back to its position.	Dusts enter into the air cut-off brake valve.	Clean the air cut-off brake valve.
	Oil or water enters into the air cut-off brake valve.	Discharge the oil or water from the storage drum, and wipe the air cut-off brake valve
The air cut-off brake valve does not exhaust air.	The tappet gets stuck	Overhaul to make the tappet move flexibly without jamming
	The return spring is broken down or the elastic force is weakened	Replace the return spring.

### 3.17.2 Troubleshooting of Electrical System

#### 3.17.2.1 Troubleshooting of starter

Problem	Possible cause	Remedy
The starter is out of operation.	Short of the accumulator capacity	Charge the accumulator according to the specifications.
	Joints of cable wires become loose, and positions contacting with iron wires are rust eaten.	Fasten the joint, and remove the corrosion
	Disconnection of the starting switch and other control circuits	Check the electric circuits and ensure a reliable connection
	Poor contact between the carbon brush and commutator	Adjust the spring pressure of the carbon bush, and clean up the commutator.
	Broken circuit or short circuit within the starter	Overhaul the starter motor
The starting of starter	Short of the accumulator	Charge the accumulator

is powerless, and the engine cannot be started.	capacity	
	Poor wire connection	Tighten the wire connections
	The commutator surface is damaged by fire and has oil stains	Polish the commutator surface or remove the oil stains
	The carbon bush is abraded too much or the spring pressure is insufficient, which causes a poor contact between the carbon bush and the commutator.	Replace or adjust
	Main contacts of the solenoid switch is ablated, which causes a poor contact	Carry out the polishing with 0# non-metallic abrasive paper.
	The bearing is abraded severely, and the armature grates the shell.	Replace the bearing.
The engine has been started, but the starter continues to rotate and makes a sharp noise.	The copper circuit switch contact disc in the starter is adhered with the two contacts	Check the circuits and finish the contacts.
	The starter lever is unhooked or the eccentric screw gets loose.	Readjust and fix
	The return spring of the lever is broken off or has lost the elasticity.	Replace the spring
	The armature shaft of the starter motor is broken off or bent.	Replace the starter motor
	The tooth surface rough-cast gets stuck.	Finish the tooth surface
	Contact adhesion of the starting relay	Replace the starting relay
	The ignition switch does not make the self-return after the starting.	Replace the ignition switch.

### 3.17.2.2 Troubleshooting the generator

Problem	Possible cause	Remedy
The generator does not generate electricity.	Wrong wiring, broken wiring and poor contact	Overhaul the circuits
	Breakage of rotor coils	Overhaul or replace the generator assembly
	Damage of commutation diodes	Replace the diode
	Poor contact of carbon bushes	Remove the dirt or replace the carbon bush
	Damage of the regulator	Repair or replace the regulator.
Charging of the generator is insufficient	The drive V-belt becomes loose.	Adjust the tensioning degree of the drive V-belt.
	The carbon bush is in poor contact, or there are oil stains at the slip ring.	Adjust the carbon bush, and clean the slip ring.
	The regulator is damaged	Replace the regulator.
	The electrolyte of the accumulator is too little or the vulcanization of the pole plate is serious, or the accumulator is too old.	Supplement the electrolyte to specified height, and the accumulator which has severe pole plate vulcanization and cannot restore the capacity should be replaced.
The charging current is too large, which may easily cause the burning-out of bulbs.	The regulation voltage of the regulator is too high	Replace the voltage regulator.

### 3.17.2.3 Troubleshooting of Battery

Problem	Possible Cause	Remedy
The capacity of the battery is insufficient, and the engine is hard to start.	The voltage of the battery is too low.	Charge the battery
	The circuit joint is in poor contact and the oxide at the terminal post is too much, which cause an insufficient charging.	Fasten the connection, remove the oxide, and coat a layer of Vaseline at the post head.
The self-discharge is too large.	Short circuits exist at the out lead of the accumulator.	Check the short circuit positions and eliminate the fault
	There is electrolyte overflowing from the battery surface, which causes the short circuit at the positive or negative pole pile.	Wipe the battery's surface and post heads with alkaline water or warm water to make its surface clean (the water cannot leak into the battery).
	Metal tools or rods are put between the positive and negative terminal posts, which has caused a serious short circuit.	Metal rods or tools are forbidden to be placed on the battery surface.

### 3.17.2.4 Troubleshooting of Instruments

Problem	Possible cause	Remedy
The pointer of water temperature gauge always points to the low temperature	Breakage appears in the circuits, and the plug position is in poor contact.	Overhaul the circuit, and remove the dirt at the plug position
	The water temperature sensor is damaged.	Replace the water temperature sensor
	The water temperature gauge is invalid.	Replace the gauge.
The pointer of water temperature gauge always points to the high temperature	The water temperature sensor is short-circuit damaged.	Replace the water temperature sensor
	There is short circuit in the circuit	Overhaul and eliminate the short-circuit faults
	The water temperature gauge is invalid.	Replace the gauge
The indication of the oil pressure gauge is abnormal	There is broken circuit or short circuit in the circuit	Overhaul and eliminate
	Broken circuit, short circuit or poor contact of the sensor	Overhaul or replace the sensor
	The oil pressure gauge is invalid	Replace the gauge.
The indication of the barometer is abnormal	Damage of the barometer	Overhaul or replace the barometer
	Leakage of the air transmission pipe	Overhaul or replace the air transmission pipe.

### 3.17.2.5 Troubleshooting of Lights

Problem	Problem Cause	Remedy
The head lamp has no high or dipped beam	Breakage of the circuits; burning-out of the short-circuit fuse	Overhaul and connect
	Poor contact or damage of the dimmer switch	Overhaul or replace
	Burning-out of the filament	Replace it by the bulb with good quality
The rear lamp does not work.	Breakage of the circuit	Overhaul and connect
	Poor contact or damage of the rear lamp	Overhaul or replace



## 4 Accessories and Spare parts

### 4.1 Accessories and spare parts

#### 4.1.1 Detailed list of Accompanying implements

No.	Code	Name	Qty	Remarks
1	JB/T 7942.1	Lever Type Grease Gun A100	1	
2	QB/T 2564.4	Slotted Screwdriver 1×5.5×125P	1	
3	QB/T 2564.5	Cross Recessed Screwdriver 6×150P	1	
4	GB/T 4388	Double Open End Wrench 10×13×135	1	
5	GB/T 4388	Double Open End Wrench 16×18×183	1	
6	GB/T 4388	Double Open End Wrench 21×24×223	1	
7	GB/T 4388	Double Open End Wrench 27×30×244	1	

#### **Important:**

1. All the spare parts and implements listed above are special parts for this machine. Please properly keep them and prevent losses in order to use them during the use, repair and maintenance of this machine. Loss of these items may affect the functions and uses of the machine and may cause the machine's performance to be reduced;
2. When repairing and maintaining the machine, please use the standard fittings required by the manufacturer. Use of substandard fittings may affect the machine's functions, service performance and service life, and even cause hidden hazards.

# 5 Maintenance Instructions

## 5.1 Technical Maintenance Procedures

Earnestly conduct the tractor technical maintenance procedures, which are effective measures to prolong the service life of tractors and reduce accidents.

According to the accumulated working hours, the technical maintenance for AK Series Tractors includes technical maintenance per shift (per 10h of working), technical maintenance per 50h, technical maintenance per 200h, technical maintenance per 400h, technical maintenance per 800h, technical maintenance per 1600h, special winter maintenance, and technical maintenance during long-term storage periods.

### **Important:**

1. All maintenance should be performed by professionally trained personnel who are familiar with the characteristics of this machine;
2. In order to make tractors work properly and to prolong the service life, technical maintenance procedures must be strictly observed.
3. In the warranty period of tractors, if non-professional personnel who are not familiar with the characteristics of this machine conduct the maintenance, or in the maintenance period specified by the manufacturer no maintenance work has been done according to the requirements, then the damage to the tractors will result in the loss of the related right of the three guarantees of this tractor.
4. Without permission, it is strictly prohibited to adjust the safety valve opening pressure of engines, hydraulic system, the safety valve opening pressure of air brake systems, the safety overflow pressure of constant overflow pump overflow valves and the opening pressure of water tank covers, otherwise it will cause damages to the tractors, which will affect the performance and will result in the loss in the related right of the three-guarantees of the tractor.

### **5.1.1 Technical Maintenance per Shift (10h of working)**

1. Remove the dust and oil from the tractor. When working in the sandy environment, the air filter should be cleaned.
2. Check whether the main fastening bolts and nuts outside the tractor are loose, especially the nuts of the front and rear wheels, tighten them if necessary.
3. Check the liquid level height in the engine oil pan, water tank, fuel tank, hydraulic lifter shell and accumulator, and add liquid to them when the liquid is inadequate. The inspection of the liquid level in the engine oil pan should be conducted 30min after the engine stops working.
4. Fill oil according to Maintenance Table 1.

5. Check whether there is any leakage of air, oil or water, and deal with the leakage if any exists.
6. Check the pressure of the front and rear tires, and fill it with air when a tire deflates.
7. Check and adjust the free path of the clutch and brake pedal.
8. Carry out maintenance of the diesel engine according to the requirements of "Routine Maintenance" in the Diesel Engine Instruction Manual.
9. Check each hydraulic oil pipe whether leaks or not. It should be eliminated if the pipe leaks.

### **5.1.2 Technical Maintenance per 50h**

1. Complete all the contents of the technical maintenance per shift.
2. Check the oil level in the oil-bath air filter and remove the dust.
3. Check the tightness of the fan belt. When pressing the belt, it should sag (15~20)mm. Adjust it if necessary.
4. The electrode connectors of the accumulator shall be coated with grease to prevent corrosion.
5. Pull out the oil drain plug of the clutch, and drain the accumulated oil.
6. Carry out maintenance of the diesel engine according to the requirements of the "1st Level Technical Maintenance" in the Diesel Engine Instruction Manual

### **5.1.3 Technical Maintenance per 200h**

1. Complete all the contents of the technical maintenance per 50h.
2. Replace the oil in the engine oil pan, and clean the oil pan and oil-absorbing plate, as well as the oil filter.
3. Clean and maintain the oil basin of the oil-bath air filter.
4. Clean the oil filter of the lifter, and replace the filter element if necessary.
5. Carry out maintenance of the diesel engine according to the requirements of the "2nd Level Technical Maintenance" in the Diesel Engine Instruction Manual.

### **5.1.4 Technical Maintenance per 400h**

1. Complete all the contents of the technical maintenance per 200h.
2. Check the oil level height in the transmission box, and add oil if necessary.
3. Check the oil surface height in the front drive axle, and add oil if necessary.
4. Check and adjust the tightness of the toe-in of the front wheel and the front wheel bearing, and adjust the tightness if necessary. Replace the lubricating oil inside the front wheel hub.
5. Check the angle of the steering wheel during idle running, adjust the angle if necessary.

6. Clean and maintain the filter of the hydraulic system.
7. Carry out maintenance of the diesel engine according to the requirements of the "3rd Level Technical Maintenance" in the Diesel Engine Instruction Manual.

### **5.1.5 Technical Maintenance per 800h**

1. Complete all the contents of the technical maintenance per 400h.
2. Replace the oil used in the hydraulic system.
3. Thoroughly clean the radiator with 25% hydrochloric acid solution, and then wash it with clear water.
4. Clean the transmission box and replace the lubricating oil, and all of these shall be done when warming up the engine.
5. Clean the oil filter screen of the hydraulic system, and check the cleanliness of the oil. When necessary, clean the cavity of the lifter shell and replace the oil with new oil.
6. Check and adjust the clearance of engine valves.
7. Check and adjust the injection pressure of the oil injection pump.
8. Clean the fuel tank and the filter in the fuel tank.
9. Carry out maintenance of the diesel engine according to the requirements of the "4th Level Technical Maintenance" of Diesel Engine Instruction Manual.

### **5.1.6 Technical Maintenance per 1600h**

1. Complete all the contents of the technical maintenance per 800h.
2. Disassemble the engine and the motor. Clean the used grease in the bearing and replace it with new grease.
3. Replace the lubricating oil in the central drive and the final drive of the front drive axle.
4. Immerse the front bearing and the release bearing of clutch into the melted heat-resisting grease, and fill them with grease.
5. Check whether the clearance and contact prints of central transmission gears are normal. Check the clearance and pre-tightened condition of bearings, and carry out adjustment if necessary.
6. After completing the maintenance, assemble the whole machine and carry out a short-term trial run. Check and adjust working conditions of each mechanism.

### **5.1.7 Special Winter Maintenance**

When the temperature is below 5°C, in addition to the "Technical Maintenance per Shift", the following provisions should be strictly observed:

1. In order to facilitate the starting of the engine, (60~80)°C hot water can be poured into the cooling system.

2. After the cold machine starts, preheat it for a while, and then carry out the operation.
3. After the operation of the tractor, if the stop time is relatively long, drain off the cooling water in the engine cooling system.
4. Select fuel and lubricating oil according to the season or the temperature.
5. In order to ensure that tractors and engines are easy to start, it is recommended that tractors be parked in an insulated machine shed or garage in the cold season.

### **5.1.8 Maintenance of Tractor during Long-term Storage Periods**

If tractors will be kept in storage shorter than 1 month, and the changing time of engine oil does not exceed 100h, these special protective measures are unnecessary. If tractors will be kept in storage longer than 1 month, it is necessary to carry out special technical maintenance on them. See “5 Storage” for details.

## Maintenance Table of AK Series Tractors

No.	Maintenance Part	Operation Content	No. of points	Maintenance Interval
1	Engine Oil Pan	Check Liquid Level Height	1	Per Shift
2	Oil-bath Air Filter	Check Liquid Level Height	1	Per Shift
3	Air Pump	Check Liquid Level Height	1	Per Shift
4	Accumulator	Check Liquid Level Height	1	Per Shift
5	Radiator (water tank)	Check Liquid Level Height	1	Per Shift
6	Engine Water Pump Shaft	Inject Grease	1	Per Shift
7	Oil Injection Pump	Check Liquid Level Height	1	Per Shift
8	Rear-Wheel Hub	Inject Grease	1	Per Shift
9	Clutch	Adjust Free Path	1	Per Shift
10	Braker	Adjust Free Path	2	Per Shift
11	Fan Belt	Check Degree of Tension	1	Per 50h of Working
12	Steering Cylinder	Inject Grease	1	Per 50h of Working
13	Four-wheel Drive Front Axle Pendulum Shaft	Inject Grease	2	Per 50h of Working
14	Front-wheel Central Pendulum Pin Sleeve	Inject Grease	1	Per 50h of Working
15	Front Axle Pendulum Shaft	Inject Grease	1	Per 50h of Working
16	Diesel Filter	Replace Filter Element	1	Per 200h of Working
17	Oil Filter	Replace Filter	1	Per 200h of Working
18	Lifter Oil Filter	Clean or Replace Filter Element	1	Per 200h of Working
19	Oil Injection Pump	Replace Lubricating Oil	1	Per 200h of Working
20	Engine Oil Pan	Replace Lubricating Oil	1	Per 200h of Working
21	Oil Basin of Oil-bath Air Filter	Maintain and Clean	1	Per 200h of Working
22	Transmission Box and Lifter	Check Oil Level Height	2	Per 200h of Working
23	Front Wheel	Inject Grease	2	Per 400h of Working
24	Clutch Pedal Hub	Inject Grease	1	Per 400h of Working
25	Brake Pedal Hub	Inject Grease	2	Per 400h of Working
26	Front Drive Axle	Check Oil Level Height	1	Per 400h of Working
27	Oil Cup of Front Drive Axle King Pin	Inject Grease	2	Per 400h of Working
28	Fuel Tank	Clean and Maintain	1	Per 800h of Working
29	Engine Intake And Exhaust Valve	Adjust Valve Clearance	4	Per 800h of Working
30	Oil Injection Pump	Adjust Oil Injection Pressure	2	Per 800h of Working
31	Transmission Box and Lifter	Replace Lubricating Oil	2	Per 800h of Working
32	Engine Cooling System	Clean and Maintain	1	Per 1600h of Working
33	Engine Cooling System using Antifreeze Fluid	Replace Antifreeze Fluid	1	Per 1600h of Working
34	Front Drive Axle Central Drive	Replace Lubricating Oil	1	Per 1600h of Working
35	Front Drive Axle Final Drive	Replace Lubricating Oil	1	Per 1600h of Working

## 5.2 Adjustment of clutch

In order to ensure the normal operation of the clutch, a clearance of (2~2.5)mm shall be kept between the end of disengaging lever 4 of the main clutch and the surface of release bearing 5; a clearance of B=(10~11)mm shall be kept between the end of disengaging lever 6 of the auxiliary clutch and the surface of release bearing 5. During the process of using, because of the continuous abrasion of the clutch friction plates, the clearance above-mentioned will gradually narrow down or even disappear. Therefore, inspection and adjustment should be carried out regularly.

1. The adjustment method for freeing the path of the clutch pedal is as follows:  
First loosen lock nut 3 on adjustment screw 2 (see Figure 4-1), and then rotate adjustment screw 2 for adjustment. Adjust the distance between the working surface of the three main clutch disengaging levers 4 and the clutch pressure plate 1, make the distance  $A=(86.5+0.2)$ mm for 25PS models, and  $A=(91.5+0.2)$ mm for 30PS or 35PS models, and finally tighten lock nut 3. Loosen nut 7 and 8, and rotate adjustment screw 8. Make the distance between the working surfaces of the auxiliary clutch disengaging lever 6 and the clutch pressure plate 1 to  $C=(78.5+0.2)$ mm for 25PS models, and  $C=(93+0.2)$ mm for 30PS or 35PS models, and then tighten the nut 8. And then ensure that the free path of the clutch pedal is (25~30)mm by adjusting the clutch rod front fork 4 (see Figure 5-2), and tighten nut 5 after the adjustment (see Figure 5-2).

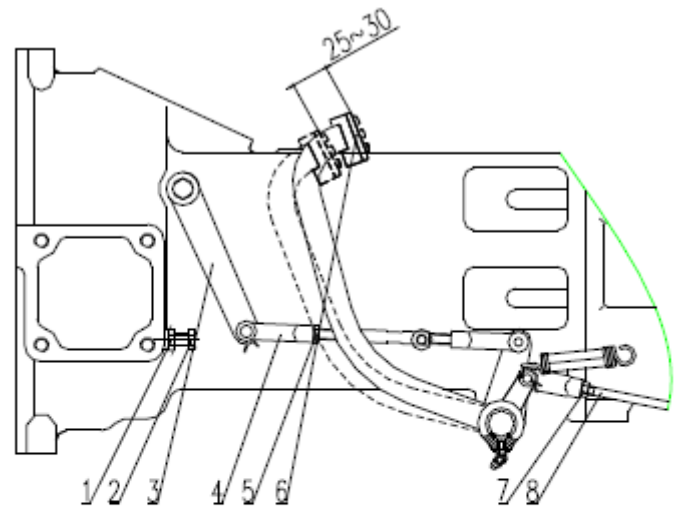

Figure 5-2 Schematic Diagram of Clutch Control System

- |                   |                         |                       |
|-------------------|-------------------------|-----------------------|
| 1. Lock Nut       | 2. Limit Screw          | 3. Release Rocker Arm |
| 4. Rod Front Fork | 5. Nut                  | 6. Clutch Pedal       |
| 7. Lock Nut       | 8. Interlocking Tie Rod |                       |
2. The adjustment method for the working path of the clutch pedal is as follows:  
Loosen lock nut 1 (See Figure 5-2) and rotate limit screw 2. Make the working path under clutch rocker arm 3 to (35~37)mm and tighten lock nut 1.

### Important:

1. In order to avoid staining the friction plate with oil, the sewage hole plug below the flywheel cover should be pulled off frequently to drain off the oil that may leak in the engine and the transmission box. If serious leakage is found, promptly identify the reasons and deal with the problems. Use gasoline (or kerosene) to clean the friction plate if necessary.
2. In order to prevent and avoid the abrasion of the friction plate, the clutch should be maintained and adjusted regularly. Do not disengage or engage the clutch arbitrarily during operation. When the clutch is released, quickly press the clutch pedal to the end. Do not operate it when it is in a half-released state to avoid damaging the clutch.

3. Operate when the clutch is in the poor adjustment state is strictly prohibited. This will accelerate the abrasion of the clutch friction plate and even burn it.
4. When installing the clutch, lithium base grease should be filled in the bearing 5 (see Figure 5-1) and the cavity of the release bearing bracket. After disassembling the clutch, check whether release bearing 5 is short of oil. If it is short of oil, put it into a heated molybdenum disulfide lithium base grease to make the grease filter into the bearing, and take it out for installation after grease cools. Do not clean the release bearing in gasoline or diesel fuel so that the grease inside the bearing does not wash away. Otherwise, the grease should be refilled.

## **5.3 Adjustment of brake**

### **5.3.1 When any of the following conditions occurs, an adjustment should be carried out:**

- The free path of the brake pedal is too great, and the brake is out of order;
- The free path of the brake pedal is too small, the gap between the friction plate and the brake drum is undersized, and the brake is frequently in a half-brake state;
- The left and right brake forces are inconsistent, and the “off tracking” phenomenon occurs.

### **5.3.2 Adjustment methods for Brake:**

- Adjustment of the free path of the brake pedal:  
The method is to loosen lock nut 3 on short bar 4, rotate brake bar control fork 2, change the length of the brake bar to make the free path (the displacement of the brake pedal from the highest position to the position where the gap between the brake drum 8 and the brake shoe friction plate 7 disappears) of the brake pedal within (20~30) mm, and make the lengths of the left and right short bars 4 consistent, and then use lock nut 3 to lock tightly.
- Adjustment for the brake’s “off tracking” phenomenon:  
When the adjustments of the left and right brakes are inconsistent and the tractor brakes while running at high-speed, the inconsistent lengths of the left and right tire mouldages--the “off tracking” phenomenon--will occur. At this time, the brake bar of the short-mouldage side should be shortened properly or the brake bar at the long-mouldage side can be lengthened properly until the lengths of the left and right tire mouldages are basically consistent and a reliable brake can be carried out, then nut 3 should be locked tightly.



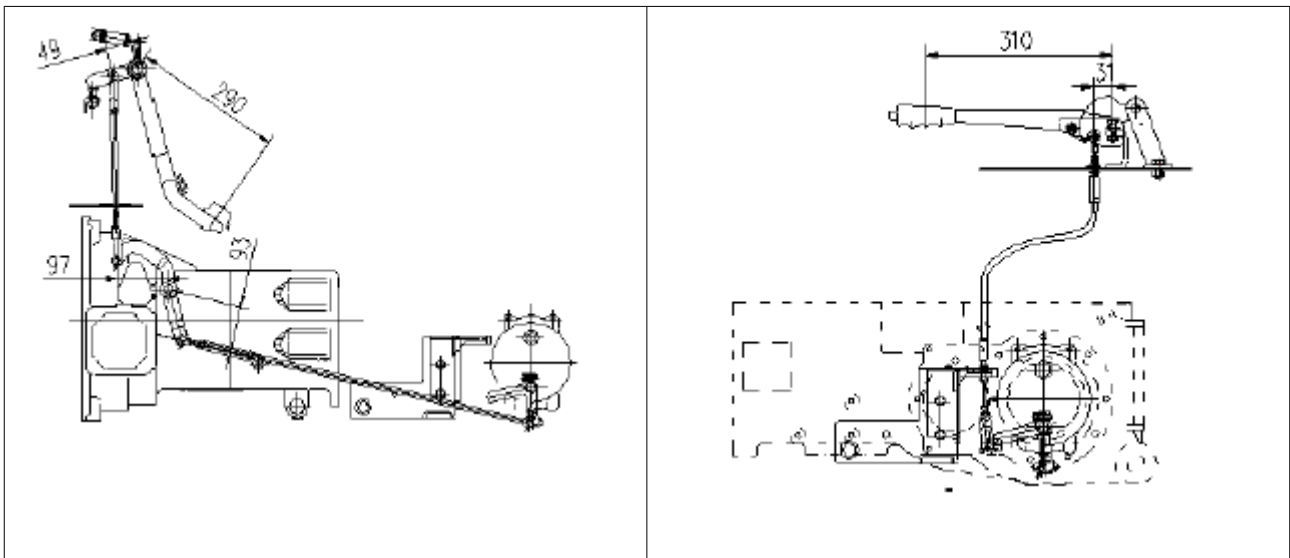

Figure 5-3 Brake System

1. Return Spring 2. Control Fork 3. Lock Nut 4. Short Bar 5. Joint Lever 6. Brake Rocker Arm
7. Brake Shoe Friction Plate 8. Brake Drum 9. Handbrake Handle 10. Brake Pedal



**Notes:** The free paths of the left and right brake pedals of the tractor must be adjusted to be consistent, otherwise, the tractor will deflect to one side when emergency braking, and accidents may occur.

## 5.4 Adjustment of Central Drive

### 5.4.1 Adjustment of cone bearing

After a period of usage, due to the abrasion of the bearings, the original pre-tightened amount will disappear gradually, and an internal clearance will emerge between two bearings. When the internal clearance is greater than 0.1mm, the cone bearing should be re-tightened.

The adjustment of the cone bearing on the second shaft to the pre-tightened amount: Adjust the tightening degree of the lock nut 1 near cone bearing 4, so that the torque of the individual rotation of the second shaft 5 is (0.7~1.1) N.m. After the adjustment is completed, lock retaining washer 2 tightly in place, and tighten lock nut 1.

Adjustment of the Cone Bearing on the differential to the pre-tightened amount. Add (or reduce) the equivalent adjusting shims 13 on both sides of the transmission box and between the bearing brackets of the cone bearing. Tighten the bolts of the two bearing brackets and rotate the second shaft. If the rotating force moment is (0.4~0.7) N•m greater than that when the differential is not installed, the pre-tightened amount is appropriate. In this case, no movement shall occur when the bevel gear wheel is pushed in the axial direction.

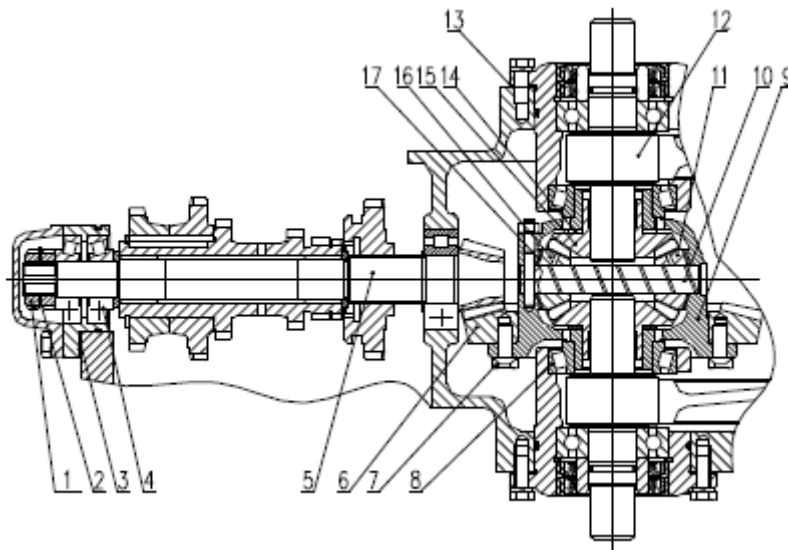

Figure 5-5 Adjustment of pre-tighten amount of Cone Bearing

- |                              |                       |                                   |                 |
|------------------------------|-----------------------|-----------------------------------|-----------------|
| 1. Lock Nut                  | 2. Retaining Washer   | 3. Adjusting Shim of Second Shaft | 4. Cone Bearing |
| 5. Second Shaft              | 6. Crown Gear         | 7. Bolt                           | 8. Cone Bearing |
| 9. Differential Case         | 10. Planet Gear Shaft | 11. Planet Gear                   |                 |
| 12. Final Drive Driving Gear | 13. Adjusting Shim    | 14. Half Axle Gear Shim           |                 |
| 15. Half Axle Gear           | 16. Planet Gear       | 17. Planet Gear Shim              |                 |

#### 5.4.2 Adjustment of Contact Moulage and Gear Backlash of Bevel Gear Pair

When the spiral bevel gear pair produces assaults or noises due to over-abrasion or abnormal contact moulage on the tooth surface during usage or when a new bevel gear pair is replaced, the contact moulage on the tooth surface and lateral clearance should be re-adjusted, and regular inspections should be completed as well.



1. Inspection of gear backlash Two methods exist for the inspection of the gear backlash. One of them is dial gauge measurement. During the measurement, place the contact finger of the dial gauge onto the big-end tooth surface of the bevel gear wheel and fix the bevel pinion; then, rock the bevel gear wheel according to the rotating direction. If the reading on the dial gauge is (0.14~0.3) mm at this time, the lateral clearance is correct. The other method is to put the lead sheet, of which length and thickness are (15~20) mm and 0.5mm respectively, or the fuse, which is bent to be “~”-shaped, between the non-engagement surfaces of the gear pair, and turn the gear pair, then the thickness measured after the lead sheet or the fuse are pressed at the big end is the normal-direction gear backlash of this position. This value shall be within the range of (0.1~0.25) mm. To be accurate, three points on the same circle of the gear shall be measured, and the average value shall be adopted.
2. Inspection of contact moulage on tooth surface The contact moulage on the tooth surface is inspected by using the staining method. Before the inspection, the bevel gear wheel and bevel pinion shall be cleaned and dried, then a layer of average red lead shall be coated on

the tooth surfaces of both sides of the big spiral bevel gear, and then rotate the gear pair to both positive and negative directions. The moulage printed on the tooth surface of the bevel pinion is the contact moulage. The ideal contact moulages are distributed in the middle of the operating gear, and near the small end. The moulages are permitted to be patchy, but the length shall be equal to or greater than 60% of the gear length, and the height shall be equal to or greater than 50% of the gear height. See Table 5-2 for the adjustment methods of the gear backlash and contact moulage on the tooth surface. During the adjustment, both the gear backlash and contact moulage will change as the bevel gear wheel and bevel pinion move in the axial direction. If the requirements for the contact moulage and gear backlash are contradicted, the contact moulage shall be mainly ensured to be correct, and the adjustment range of the gear backlash can be enlarged appropriately, especially when adjusting after the wear and tear of the gear and bearing, but the gear backlash shall be equal to or greater than 0.1mm. During the normal usage of the tractor, as long as the contact moulage is normal, the only enhancement of the gear backlash is not required to be adjusted. However, after the overhaul of the tractor, or when a new pair of central drive gear or bearing is replaced, careful adjustment must be carried out. At the same time, the gear backlash and contact moulage shall be ensured.

**Important:** The bevel gear wheel and bevel pinion of the central drive are a pair of paired gear. They shall not be mistaken when installed. They shall be replaced by pair during the replacement. It is better to replace them together with the bearing; otherwise, their service life will be affected.

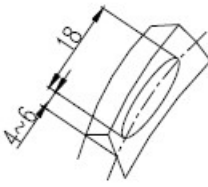
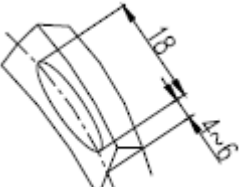
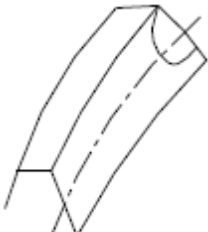
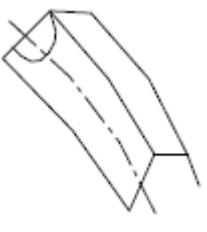
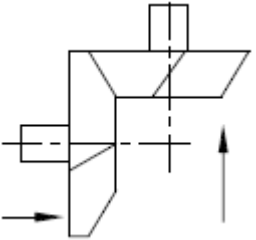
**Table 5-2 Adjustment of Moulage on Small Spiral Bevel Gear of Central Drive**

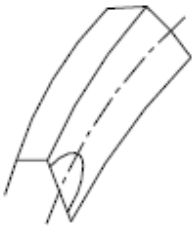
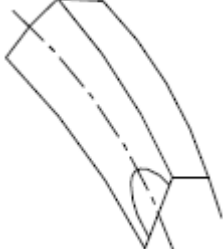
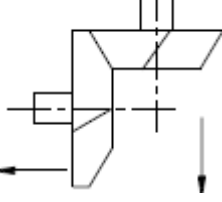
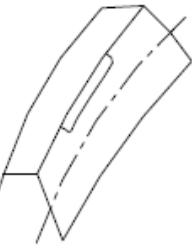
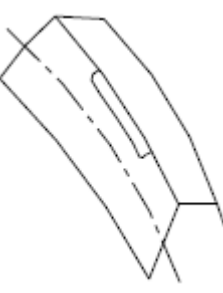
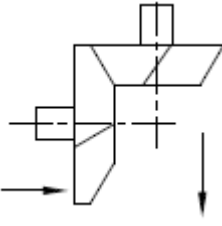
No.	Description	Moulage on Small Spiral Bevel Gear of Forward Gear	Moulage on Small Spiral Bevel Gear of Reverse Gear	Instructions and Illustrations of Adjustment
1	Normal Moulage			<p>During the forward gear, the total length of all the moulages on the concave of the small spiral bevel gear is equal to or greater than 60% of the gear width and the height is equal to or greater than 50% of the gear height, and the moulages are distributed in the middle of the gear height and near the small end. During the reverse gear, all the moulages on the concave of the small spiral bevel gear are the same with the above.</p>
2	Abnormal Moulage			<p>1. Add the adjusting shims at the position of the front bearing case of the second shaft, to</p> <div style="text-align: right;">  </div>

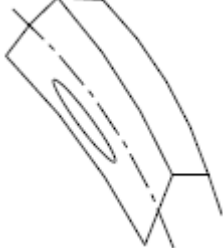
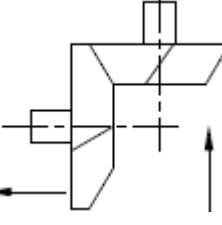
				<p>make the small spiral bevel gear move forward;</p> <p>2. If the clearance is big, move the bevel gear wheel to the right.</p>
		 	<p>1) Reduce the adjusting shims at the position of the front bearing case of the second shaft, to make the small spiral bevel gear move backward;</p> <p>2) If the clearance is small, move the bevel gear wheel to the left.</p> 	
		 	<p>1) Reduce the adjusting shims at the position of the front bearing case of the second shaft, to make the small spiral bevel gear move backward;</p> <p>2) Reduce the adjusting shims at the position of the left bearing case, and correspondingly add them to the right side, to make the bevel gear wheel move right.</p> 	
		 	<p>1) Add the adjusting shims at the position of the front bearing case of the second shaft, to make the small spiral bevel gear move forward;</p> <p>2) Reduce the adjusting shims at the position of the right bearing case, and correspondingly add them to the left side, to make the bevel gear wheel move left.</p> 	

**Note:** The line arrows represent the direction to move the gear

## 5.5 Adjustment of steering system

### 5.5.1 Use Precautions of Full Hydraulic Steering System

The AK Series 4-wheeled Tractors adopt the full hydraulic steering mode, as shown in the following figure. Before each tractor leaves the factory, the steering system must be adjusted correctly. When using such a tractor, users should pay attention to the following aspects:

- All the threaded connections should be often checked. If any loose connection occurs, it should be tightened in time. No leakage should occur in any connection when the full hydraulic steering system is working.
- During the use, if steering becomes hard or fails, check the tractor to find out the reasons. Do not turn the steering wheel forcibly or even take apart the steering gear so as to avoid any damage to the parts. It is strictly forbidden that two persons turn the steering wheel at the same time.
- When the hydraulic steering system is installed, the steering gear should be on the same axis line with the steering shaft, and a certain gap should exist between them in the axial direction. After the hydraulic steering system is installed, check whether the steering wheel can return flexibly.
- The cleanness of the oil fluid should be guaranteed. For this reason, the filter element and oil fluid should be often checked. The check method is as follows: Drop a drop of oil fluid onto a blotter. If there is a dark centre in the oil stain, the oil fluid should be replaced.
- After the new oil is put in, the air in the cylinder should be completely drained. The method for draining the air is as follows: Loosen the bolt head of the steering cylinder, and make the oil pump run at a low speed to drain the air until there are no bubbles in the outgoing oil. Remove the connection between the piston rod of the steering cylinder and the tumbler, and turn the steering wheel to move the piston to the leftmost or rightmost position (the piston should not stop in these two positions).
- The diverter valve is a precision component and cannot be removed in normal cases. If the diverter valve must be removed, it should be removed at a clean place and should be purged with clean gasoline or kerosene.
- Before leaving the factory, the pressure of the diverter valve has been adjusted correctly. Therefore, do not remove or adjust this valve by yourselves.

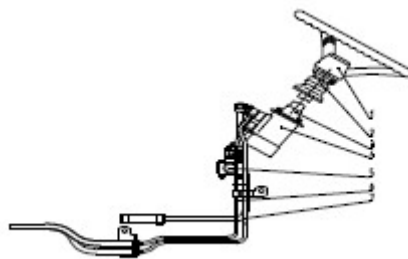

Figure 5-6 Full Hydraulic Steering System

1. Steering Wheel
2. Jacket
3. Steering Column
4. Steering Gear
5. Diverter Valve Assembly
6. Right Oil Pipe of Steering Gear
7. Left Oil Pipe of Steering Gear

## 5.5.2 Adjustment of Front-wheel Toe-in

During the use of the tractor, the front-wheel toe-in changes due to the deformation and abrasion of the steering mechanism and the front-shaft parts. If the toe-in is not adjusted in time, the abrasion of the tires of the front wheels will be accelerated. The adjustment steps for the front-wheel toe-in are as follows:

- Park the tractor at a flat place and locate the front wheels in the straight-line travel positions;
- Measure the distance between the front ends of the two front wheels (namely, Distance A) and the distance between the rear ends of the two front wheels (namely, Distance B) on the same horizontal height as the centres of the front wheels;
- Loosen the lock nut 3 at the two ends of the left steering tie rod 1 and right steering tie rod 4, and turn the ball stud 2. When  $B-A = (0\sim 4)$  mm, lock the left steering tie rod 1 and right steering tie rod 4 by using the lock nut 3. Notes: The left side and the right side should be symmetrical during the adjustment.

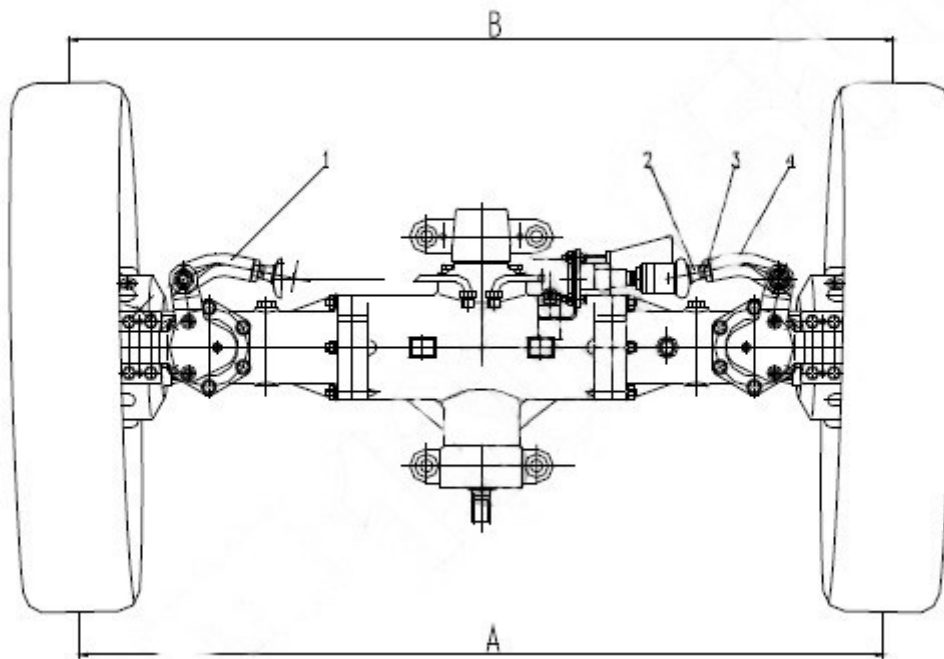

Figure 5-7 Adjustment of Front-wheel Toe-in

1. Left Steering Tie Rod      2. Ball Stud      3. Lock Nut      4. Right Steering Tie Rod

### 5.5.3 Adjustment of Span between Rear Wheels

The adjustment of the rear wheels refers to conduct step less regulation by changing the fixed position of the rear-wheel hub on the driving shaft or to conduct stepped regulation by reversing the rim of the driving wheels and exchanging the left and right driving wheels.

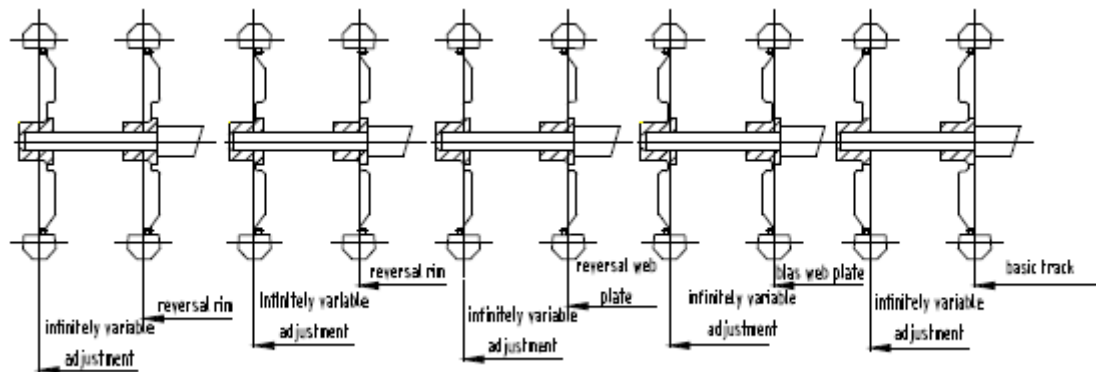

Figure 5-8 Adjustment of Span between Rear Wheels

## 5.6 Adjustment of front drive axle

### 5.6.1 Adjustment of Central Drive of Front Drive Axle

- 2 tapered roller bearings on the bevel pinion shaft of the front drive axle and 2 tapered roller bearings in the left part and right part of the differential case are all pre-tightened. During the use, axial internal clearance occurs between the bevel pinion shaft and the differential case due to the abrasion of the bearings. Therefore, these components should be checked every 1,600h. The adjustment of the bearings on the bevel pinion shaft is conducted through the adjustment of the thickness of the adjusting shim 5 so that the torque of the individual rotation of the bevel pinion shaft is  $(0.7\sim 1.0) \text{ N}\cdot\text{m}$ . Finally, the nut 6 should be tightened.
- For the adjustment of the bearings on the differential case, select an appropriate adjusting shim 1, tighten the adjusting nut 2, lock the stop pad 3, and then turn the bevel pinion shaft. If the rotating force moment is  $(1.4\sim 1.7) \text{ N}\cdot\text{m}$  greater than that when the differential is not installed, the

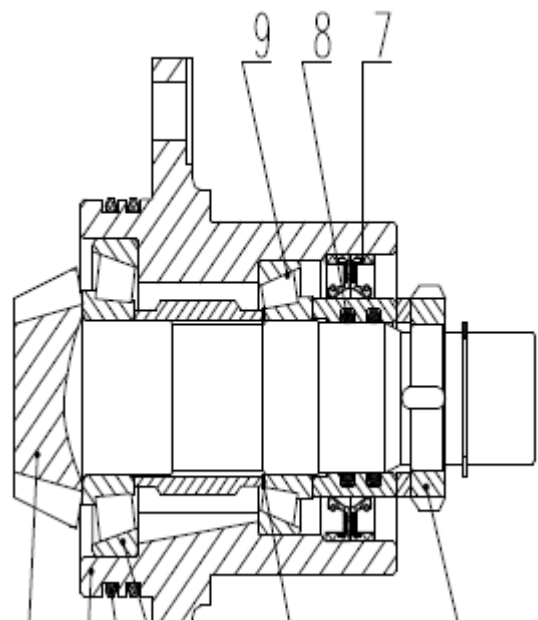

Figure 5-9 Adjustment of Central Drive of Front Drive Axle  
 1. Drive Bevel Pinion Shaft  
 2. Drive Bevel Pinion Shaft Bracket  
 3. O-ring  
 4. Bearing  
 5. Adjusting Shim  
 6. Nut  
 7. Oil Seal  
 8. O-ring  
 9. Bearing

pre-tightening amount is appropriate. In this case, no movement should occur when the bevel gear wheel is pushed in the axial direction.

- The gear backlash and engagement imprint are checked through the same method as that used for checking the central drive of the rear axle.

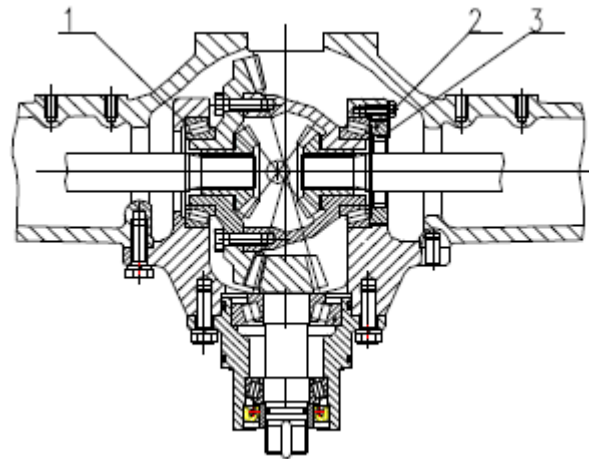

Figure 5-10 Adjustment of Bearings on Differential Case 1. Adjusting Shim 2. Adjusting Nut 3. Stop Pad

### 5.6.2 Adjustment of Side Drive of Front Drive Axle

The engagement imprint and gear backlash between the driving gear and driven gear of the level-1 middle drive of the side drive of the front drive axle are adjusted through the adjusting shim 1. The engagement imprint and gear backlash between the driving gear and driven gear of the level-2 end drive are adjusted through the adjusting shim 5. The gear backlash in these two positions should be (0.25~0.45) mm.

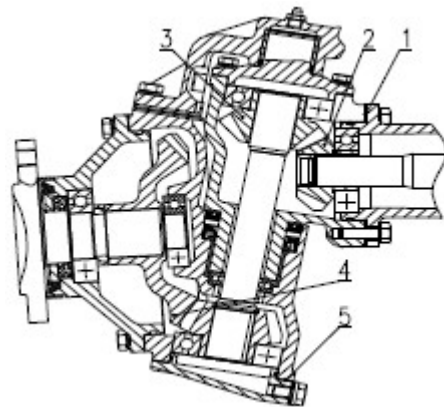

Figure 5-11 Adjustment of Side Drive of Front Drive Axle  
 1. Adjusting Shim 2. Driving Gear of Middle Drive 3. Driven Gear of Middle Drive 4. Driven Gear of End Deceleration  
 5. Adjusting Shim

### 5.7 Adjustment of Hydraulic Lifting Mechanism

First, put the farm implements rise and fall control handle in the neutral position as shown in the following figure. Then, adjust the distance between the stop piece on the push rod and the stop pin fixed on the lift shaft. In this way, the rise and fall positions of the farm implements can be controlled.



### 5.7.1 Adjustment of the Highest Rise Position of Farm Implements

During the adjustment, first turn the outer lift arm 6 toward the rise direction so that the distance from the lower end of the inner lift arm 7 to the spacer pin 8 of the rear-end cover of the lifter is adjusted to about 5mm. Adjust the distance between the inner-side lock nut 5 and the stop pin 4 to (9~10) mm, and then tighten the two lock nuts onto the push rod 2.

### 5.7.2 Adjustment of the Lowest Fall Position of Farm Implements

During the adjustment, first turn the outer lift arm 6 toward the fall direction to the lowest position (in this case, the piston in the cylinder is pushed close to the bottom dead centre), and adjust the distance between the stop piece 3 and stop pin 4 on the push rod 2 to (9~10) mm. Then, tighten the stop piece 3 onto the push rod by using the bolt on the stop piece 3.

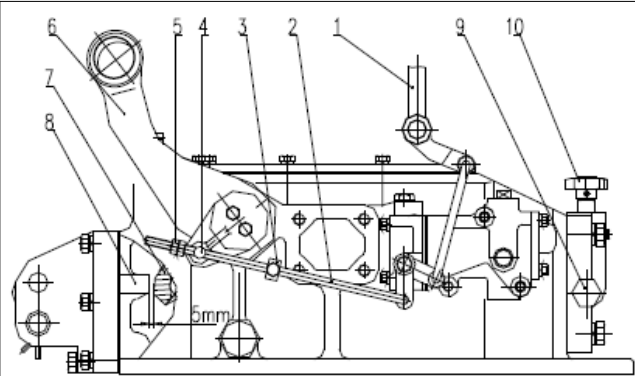

Figure 5-12 Adjustment of Rise and Fall Positions

1. Control Handle
2. Push Rod
3. Fall Stop Piece
4. Stop Pin
5. Lock Nut
6. Outer Lift Arm
7. Inner Lift Arm
8. Spacer Pin
9. Hydraulic Output Screw Plug
10. Regulating Valve

## 5.8 Use and Maintenance of Air Filter

### 5.8.1 Use Instructions of Filter

- When the filter blocking alarm equipment generates an alarm or after the filter works for (50~100) hours, the main filter element should be maintained;
- If there is a lot of dust in the working environment, the filter element should be maintained every 8 hours or every working period;
- Replace the filter element when the dust on it cannot be removed after the maintenance or the filter element is damaged.

### 5.8.2 Maintenance Method for Filter

- Take out the filter element, use a brush to clean the inner case of the air filter, and remove the dust from the rubber dust bag;
- Turn the filter element, and meanwhile use compressed air of less than 500KPa to blow the dust from the inside of the filter element to the outside;
- Re-install the filter element.

**Important:** Correct use and maintenance of the air filter are associated with the service life of the engine. Therefore, the air filter should be always kept clean. When the tractor works in a farmland, the air filter should be checked and cleaned after each working period and the oil should also be replaced. When the tractor works with a harvester, locating the filter in a position one level higher than the original position will bring better effects. For the maintenance of a dry-type air filter, it is forbidden to wash the filter element with oil or water.

## 5.9 Adjustment of tensioning Degree of Fan Belt

Press the middle part of the fan belt with the thumb. The exerted force should be (29.4~49.0) N, and the pressing distance should be (15±3) mm. If this requirement cannot be met, adjustment should be made accordingly. The adjustment method is as follows:

Loosen the fixing nut on generator regulating support, wrench the generator outwards to tension the belt, and then tighten the fixing nut on generator regulating support.

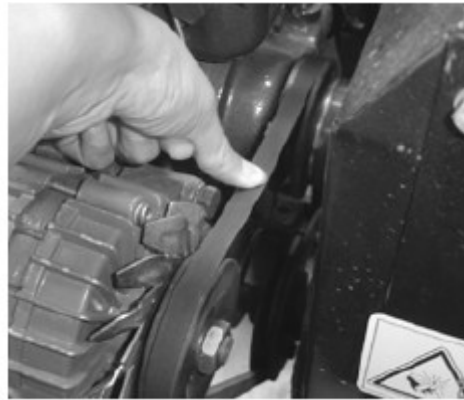

Figure 5-13 Adjustment of Tensioning Degree of Fan Belt

## 5.10 Check of Oil Mass of Engine Oil Pan and Replacement of Oil

(1) Pull out the oil dipstick A in left front of the oil pan, and check whether the oil level is located between the upper scale mark and the lower scale mark. If the oil level does not reach the lower scale mark, oil should be added until the oil level reaches the specified height.

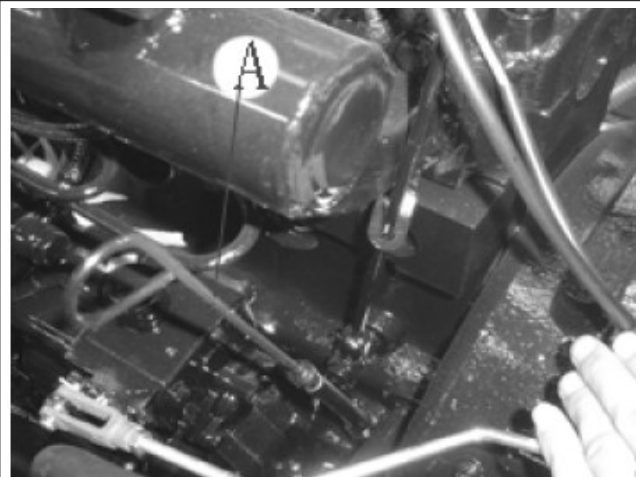

Figure 5-14 Check of Oil Mass of Engine Oil Pan

(2) Before maintenance and oil replacement, the engine should be pre-warmed. After the oil temperature reaches 50°C~60°C, screw off the oil drain plug A under the oil pan to drain out the dirty oil, and clean the oil pan. Then, add new oil.



Figure 5-15 Replacement of Oil in Engine Oil Pan

**Important:** It is forbidden to mix old and new oil or oil of different brands for use, so as to avoid any damage to the engine. The oil should be replaced strictly according to the period specified in the Diesel Engine Instruction Manual.

### 5.11 Maintenance of Fuel Filter

The fuel filter is located in left front of the engine. It is not allowed to wash the paper filter element of the filter. The filter element should be replaced each time when the engine works for 200 hours. For the detailed maintenance process, refer to the instruction manual of the manufacturer.



Figure 5-16 Maintenance of Fuel Filter

### 5.12 Maintenance of Oil Filter

The oil filter A is located under the bottom centre of the left side of the engine, and should be replaced according to the technical requirements each time when it works for 200 hours. The oil filter should be replaced as a whole, and should be tightened during installation. For the detailed maintenance process, refer to the instruction manual of the manufacturer.

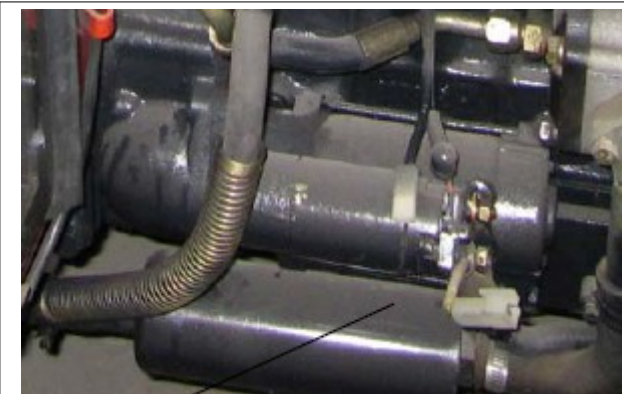

Figure 5-18 Maintenance of Oil Filter of Lifter

## 5.14 Check of Front Drive Oil Level

When the oil level of the front drive housing needs to be checked, the oil dipstick attachment 'A' should be screwed off. The oil level should be in the range of the oil dipstick graduations. Otherwise, oil should be added. When the oil needs to be replaced, the oil drain plug of the central drive and the oil drain plugs of the left and right end drive should be screwed off to drain out the dirty oil. Then, these plugs should be tightened, and new oil should be added from the 'A' position. After a while, if oil leakage occurs in the B position, it indicates that the front drive housing is filled up.

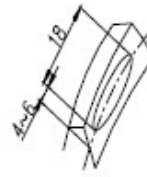

Figure 5-29 Check of Front Drive Oil Level

## 5.15 Maintenance of Transmission System

Pull out the oil dipstick 3, which is located at the right-back side of the transmission box (as shown in Figure 4-21), wipe it, and then insert the oil dipstick. If the oil level does not reach the lower scale mark of the oil dipstick, transmission oil should be added so that the oil level can be located between the upper and lower scale marks of the oil dipstick. The measurement should be made 5 minutes after the oil is added. To replace the lubricating oil, remove the oil drain plug from the bottom of the transmission box to drain out the dirty oil. Then, tighten the oil drain plug and add new oil.

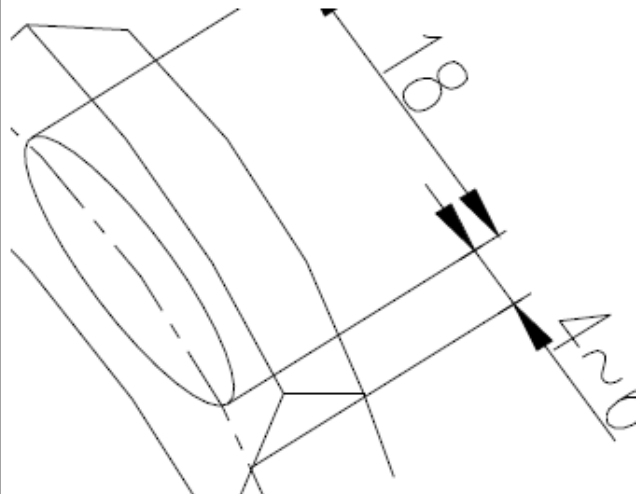

Figure 5-20 Maintenance of Transmission System

1. Refill Opening 2. Refill Opening Cap  
3. Oil Dipstick 4. Oil Dipstick Bracket

**Note:** When the oil level needs to be checked, the tractor should be located on a level ground, and the engine should be stopped. Then, the oil level can be checked

## 5.16 Maintenance of Lifter

Screw off the refuelling plug located under the lifter (see the picture on the right). If the oil level is below the oil dipstick graduation, please fill the oil.



To replace the lubricating oil, screw off the oil drain plug A located under the lifter to drain out the dirty oil. Then, tighten the plug to refill new oil.

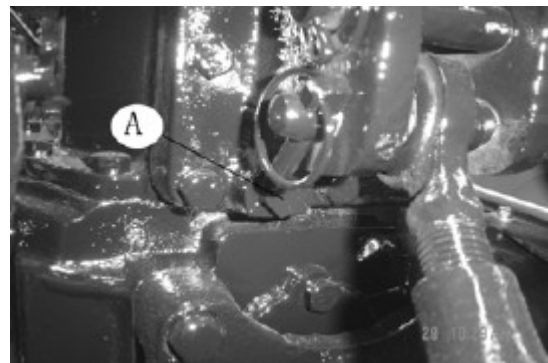

**Note:** Please park the tractor on the flat surface, and then drop the lifter arm to the lowest position. Stop the engine and then check the oil level.

## 5.17 Maintenance of Fuel Tank

Drive the tractor to a level ground, stop the engine, and then remove the oil drain plug located under the fuel tank to drain out the oil deposits from the bottom of the fuel tank.

## 5.18 Check of Inflation Pressure of Tire

Use a barometer to measure the pressure of the tires. For details about the inflation pressure of the tires, refer to the List of Technical Specifications of AK Series Tractors.

**Note:** Excessively low or high pressure of the tires will shorten the service life of the tires. Also, it will affect the driving and manipulating of the tractor, and thus accidents may occur.

## 5.19 Maintenance of Engine Cooling System

The engine cooling fluid can be boiled tap water or anti-freezing liquid. The validity period of the anti-freezing liquid is 2 years or 1,600 hours.

After the validity expires, the anti-freezing liquid should be replaced and the cooling system should be rinsed. Then, new anti-freezing liquid should be added. The method for removing the water deposits from the cooling system is as follows:

Fill the cooling system with a solution in which 750g caustic soda and 150g kerosene is added per 10L water. After the engine runs at a medium speed for (5~10) minutes, store the solution at a proper place for (10~12) hours (Note that the solution should be kept warm in winter so as to avoid freezing). Then, restart the engine and make it run at a medium speed for 20 minutes. Afterwards, stop the engine and drain out the solution. After the engine cools down, insert the water pipe into the water tank to rinse it. At this moment, the water drain valve at the bottom of the water tank should be opened.

After the water tank is cleaned, close the water drain valve, add water, and make the engine run for 20 minutes. Then, drain out the water. After the engine cools down, add new anti-freezing liquid or cooling water according to the relevant requirements.



**Important:** In winter, for a tractor that does not use anti-freezing liquid, the cooling water should be drained out when the temperature of the cooling water falls below 70°C and the engine runs at idle speed. In this way, the tractor body will not burst due to freezing of the cooling water.

## 5.20 Exhaust of Fuel System

If the tractor is not used for a long time, or when the diesel filter element is replaced, or when the oil tank is kept empty, air may come into the fuel pipeline. The air in the fuel system will make it hard to start the engine. Therefore, after the oil tank is filled up and the oil line switch is on, perform the following steps to discharge the air from the fuel system:

- Loosen the air bleed screw A of the fuel filter, and then shake the pull button C of the fuel transfer pump up and down until there are no bubbles in the diesel oil flowing out from the air bleed screw hole.
- Tighten the air bleed screw A, and loosen the air bleed screw B of the fuel injection pump. Then, shake the pull button C of the fuel transfer pump up and down until there are no bubbles in the diesel oil flowing out from the air bleed screw hole. Afterwards, tighten the air bleed screw B.

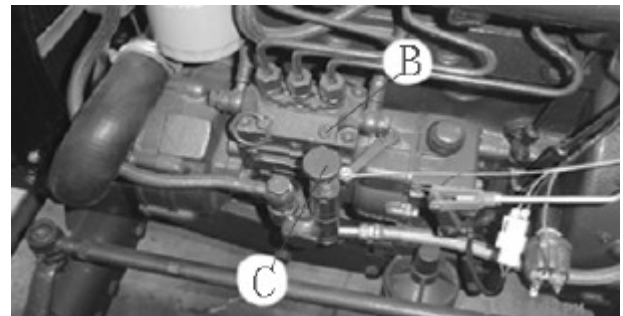

**Important:** The engine must use light diesel oil that complies with the relevant specifications. Generally, 0# light diesel oil should be used in summer, and -10# light diesel oil should be used in winter. The diesel oil used must be pure. Before use, it must be precipitated and purged for a minimum of 48 hours. Otherwise, the service life of the engine will be affected.

## 6 Storage

After finishing staged operations or in the case of parking for a rather long time (exceeding 1 month) due to some reasons, the tractor must be properly kept and sealed. The tractor should be kept in an environment of good conditions to avoid the corrosion, ageing and deformation of machine parts.

Before the sealing, the tractor should be completely cleaned, and all the connecting pieces should be adjusted and fastened. The technical maintenance stipulated should be finished on the basis of working time, to keep the tractor in good technical conditions.

**Important:** It is crucial to carry out the scientific keeping and special maintenance for the tractor in long-term non-use period. Otherwise, the degradation rate of technical conditions of the tractor will be faster than that in the working period.

### 6.1 Reasons for Damage of Tractor during Storage

**6.1.1 Corrosion and pollution:** In the period of parking, the dust and moisture in the air may easily enter the machine interior from joints and orifices, etc., which will produce pollution and corrosion to the parts. The deterioration, rust stains, agglutination obstruction or jamming, and obsolescence at last may happen to the relative movement surfaces, such as piston, valve, shaft and gear because of the loss of flow due to the long-term stay in one position, and the lack of pressure lubricating oil film protection.

**6.1.2 Ageing:** The ageing, deterioration, embitterment, function loss or corrosion and putrescence may happen to the rubber and plastic parts, etc. due to the ultraviolet ray in the sunlight.

**6.1.3 Deformation:** The plastic deformation may occur to the parts, such as transmission rubber belting and tires due to the long-term stress undertaken.

**6.1.4 Others:** The electrical parts are affected by damp and self-discharge of the accumulator, etc.

### 6.2 Sealing and Storage of Tractor

**6.2.1** Check the tractor carefully and eliminate the existing faults before the sealing and storage, so as to keep good technical conditions. The external surface of the tractor should be cleaned up.

**6.2.2** Empty the antifreeze fluid and anti rust agent in the radiator, cylinder and water pump, as well as the lubricating oil in the transmission system, and the hydraulic oil in the hydraulic system.

**6.2.3** Remove the accumulator, coat the grease on its terminal posts, and store it in the room which is protected from light, ventilated and with the temperature equal to or greater than 10#.

**6.2.4** Empty the engine oil while it is hot and fill with new engine oil. Then let the engine run for a few minutes in the small throttle to make the engine oil adhere to the surfaces of all the moving parts evenly.

**6.2.5** Fill all the lubricating points with grease.



**6.2.6** Coat the electrical contacts, connectors and metal parts surfaces unpainted with dehydrated Vaseline [heated to (100~200)#].

**6.2.7** Untie the fan belt of engine. Remove the belt, pack it and store it separately, if necessary. The antirust agent should be spray-coated inside the belt groove. Paint should be made up for the tractor surfaces where paints peel off.

**6.2.8** Empty the diesel oil in the fuel tank and clean the tank.

**6.2.9** Use the protective materials (for instance the canvas, waterproof cloth or oil paper) to seal the unsealed mouths of pipes, such as the air inlet and outlet to prevent the foreign materials, dusts and moisture from entering.

**6.2.10** Put all the control handles in the neutral position (the electrical system switch included); make the front wheel of the tractor in a proper position and put the hanging rods in the lowest position.

**6.2.11** Put up the tractor with wooden shelf to make the tire free of load. Check the tire pressure on a regular basis.

**6.2.12** The tractor should be parked in the machine warehouse or carriage shed, and the environment should be ventilated and dry. It is strictly prohibited to store the tractor together with the items and gases with corrosives. If the conditions do not permit, and the tractor has to be parked in the open air, then a relatively high and dry platform must be selected, and the tractor should be covered with a waterproof cloth.

**6.2.13** The parts and accompanying tools removed from the tractor should be cleaned up, packed and stored in a dry storehouse.

### **6.3 Maintenance of Tractor during Sealing and Storage**

**6.3.1** The aforesaid requirements for the tractor sealing and storage must be met for the tractor during the sealing and storage.

**6.3.2** The check for abnormalities, such as rustiness, corrosion, aging and deformation of the tractor and its spare parts should be carried out monthly, and the problems found should be eliminated in time.

**6.3.3** The engine crankshaft should be revolved for 10~15 cycles every 2 months to prevent the internal rustiness. The old grease should be cleared up and replaced with new one in the lubricating positions where the grease filling is required.

**6.3.4** The tractor should be started to run at a low speed for 20~30 minutes every 3 months to check the abnormalities in all the parts.

**6.3.5** Clean the dusts on the top surface of the accumulator with dry clothes and conduct maintenance for the accumulator according to the "Instruction Manual for Accumulators" on a regular basis. The accumulator still carries out self-discharge even though it is not used, so one charge should be supplemented for the accumulator every month.

**Important:** If the user is not possessed with the conditions of rust protection, and the tractor is required to leave unused for several months or longer, then the engine and oil filter should be replaced as a minimum. In addition, the tractor should be started once to run at a low speed for 20~30 minutes every month to check the abnormalities in all the parts. The outside of tractor should be kept clean and dry to prevent rustiness for the tractor.

## **6.4 Unsealing of Tractor**

**6.4.1** Clear up the grease used for rust protection.

**6.4.2** Open all the sealed mouths of pipes. Clean the tractor.

**6.4.3** Add the coolant, engine oil and diesel oil according to the regulations, and fill up all the lubricating points with grease.

**6.4.4** Check the voltage and install the accumulator in the light of the “Instruction Manual for Accumulators”.

**6.4.5** Clear up the anti rust agent in the fan belt groove, and install the belt. Adjust the tightness of the driving belt according to the technical requirements (See the Instruction Manual for the Use and Maintenance of Engine).

**6.4.6** Push in the accumulator and coat the binding posts with Vaseline.

**6.4.7** Check the tightening conditions of all the circuits and pipelines.

**6.4.8** Control the tractor as required in the instruction manual.

**Note:** See the “Instruction Manual for the Use and Maintenance of Engine” for details of sealing and storage, and unsealing of the engine.

# 7 Delivery, Acceptance and Transportation

## 7.1 Delivery and Acceptance

When purchasing the tractors, the acceptance should be conducted on the purchased machines by the users. The check of following aspects should be emphasised:

- Whether the accompanying documents are complete
- The accompanying documents include: Instruction Manual of Tractor, Product Qualification Certificate, Three Guarantees Service Evidence (guarantees for repair, replacement and refund of faulty products), Packing List Of Accompanying Items and ‘Accompanying Technical Documents of Engine’(from the engine supporting manufacturers) and Tractor Spare Parts Drawing Volume. Check the Product Qualification Certificate, Three Guarantees Service Evidence and the corresponding numbers on the ‘Accompanying Technical Documents of Engine’ for their accordance with the real objects.
- Whether the accompanying items are complete  
Check the accompanying items of the tractor according to the Packing List Of Accompanying Items. The accompanying items include accompanying spare parts and tools. The accompanying items of engine are subject to the stipulations in ‘Accompanying Technical Documents of Engine’ (if you have any questions, please contact the dealer).
- Whether the machine is in good conditions  
Changes may happen to the technical conditions of the machine, as it has been consigned or transported by driving, therefore the user should make further confirmation on the machine conditions when purchasing.

## 7.2 Transportation

When transferring the tractors, strictly abide by the traffic regulations if they are self-propelled. The distance between two tractors should be kept for 60m as a minimum, so as to avoid the crash due to accidents. If the method of truck loading transportation is adopted, then the following points should be achieved:

- The loading and unloading of tractors should be carried out in a flat place.
- The aid of unloading decks should be taken in the loading and unloading of tractors.
- There must be an assistant on the site for guidance, and the irrelevant personnel are not allowed to approach.
- Put the hanging rods in the lowest position after the loading, and then pull the hand braking. Shift into reverse, pull out the launch key, lock the car doors and turn off the main switch of power supply.
- Fix the four tires in the shape of “八” (two arc lines opposing to each other symmetrically ) in the front and back with iron wires. The front and back of tires should be reliably jammed with wedge blocks, and the rear bridge beam should be pulled with iron wires.
- The back mirror should be turned inwards as far as possible, and take it down if necessary.

- Adequate care should be paid to whether it is ultra-high when passing through the culverts and bridges, and sufficient deceleration should be carried out when turning.
- During the unloading, release the hand braking at first, and then shift to the forward gear and put the machines down at the lowest speed.
- The special scheme of piling rack or complete machine boxing should be designed during the container transportation, to ensure the reliable fixation of tractors in the containers.

**Important:**

1. The stop braking of the loading trucks should be tight, and the front and rear wheels should be reliably jammed during the loading and unloading of tractors.
2. The tractors should run at the lowest speed during the loading and unloading of tractors.

## 8 Technical Specifications

Tractor Model		AK404
Type		4 wheel drive
Dimensions	Length with FEL	3540mm
	Width	1600mm
	Height	2400mm
	Front wheel tread	1200mm
	Rear wheel tread	1300mm
	Wheel base	1800mm
	Min ground clearance	320mm
Weight with FEL and ballast		2080kg
Engine	Type	4 cylinders, water cooled and 4 stroke
	Rated power	40HP
	Fuel	Diesel
Tire	Front tire (Agri)	9.5-20
	Rear tire (Agri)	14.9-28
	Front tire (Radial)	260/70R20
	Rear tire (Radial)	380/85R24
	Front tire (Industrial)	400/60-15.5
	Rear tire (Industrial)	600/55-22.5
Fuel tank capacity		40L
Clutch		Dry friction, two stage, ceramic disc
Swing draw bar		Yes (tow bar + swing draw bar)
Cabin		Optional
Steering		Power steering
Transmission box		8F + 8R shuttle shift
Speed range		Forward (2.46-34.78) Reverse (2.15-30.49)
Hydraulic output		2 sets rear remotes / 40L / min
Suspension type		Three point (Cat 1)
Lift capacity at 610mm behind hitch point		1150kg
PTO shaft		Non-independent type 540/1000 r/min I35 Rectangle spline with 6 teeth

## 9 Disassembly and disposal

After the machine reaches its due service life, and for your personal safety and the protection of social environment, please deliver it to the licensed company specialised in the disassembly and recycle operation. When do it, please disassemble in sequence of from top to bottom, then outside to inside. In case of large object or heavy mass, the special hoisting mechanism must be used. Please handle the battery to the special battery recycling company. Please collect the waste oil and so on for proper treatment. Do not reject them randomly, or they may cause the pollution risk to the environment

**Warning:** The battery electrolyte is corrosive; do not let it splash into on your eyes, skin and clothes. If such happens, you must use the clear water to clean it immediately, and go to the hospital for treatment as soon as possible, in order to avoid the accidental injury.

**Warning:** Replaced the battery acid liquor can cause the pollution to the environment, do not splash it at random. The replaced machine oil is reject oil material, it cannot be discarded at will so as not to pollution the environment.

We kindly remind you, when or after knocking down; the improper placement will cause the personal injury on lack of special tools and practical experience.

**Warning:** When disassembling the large or heavy mass object, the special hoisting mechanism must be used, and be careful of your personal safety!

# 10 Warranty Items

## 10.1 Basis of Products' Warranty

The warranty of Wheeled Tractors of AK Series is carried out according to the following documents and laws and regulations.

Provisions on the Liability for the Repair, Replacement and Return of Agricultural Machinery Products State Economic and Trade Commission [1998] Document No.123

Law of the People's Republic of China on Product Quality

Law of the People's Republic of China on the Protection of Consumers' Rights and Interests

## 10.2 Situations of Unavailable Warranty

The warranty is unavailable in some cases in the light of the relevant laws and regulations. See the accompanying document Three Guarantees Service Evidence for details.

**Note:** Some behaviours may lead to the invalidation of warranty conditions. See the Three Guarantees Service Evidence for details.

**Note:** If the users modify the tractor by themselves or use the tractor in the areas beyond those stipulated in the instruction manual, then the warranty from the manufacturer will be unavailable for this tractor. Please be aware of this.

# 11 Appendices

## 11.1 Oil and Solution Use for Tractor

Places to Use Oil or Solutions	Oil and Solution
Fuel Tank	Fuel oil D-975 of the American Society for Testing and Materials (ASTM) is used. Grade 2-D is used at the general temperature and Grade 1-D is used when the surrounding temperature is below 5#.
Engine Oil Pan	Viscosity grades of engine oil pan, injection pump, oil of governor and oil-bath air filter all conform to the viscosity classification of Society of Automotive Engineer (SAE). SAE10W is used when the temperature is below -5#. The multi-grade oil of SAE15W/40 for all seasons is used when the temperature is above -5#. The quality class conforms to the Standard CD of American Petroleum Institute (API).
Water Radiator	<p>When the surrounding temperature is above 4#, clean soft water is used for the cooling system of the tractor</p> <p>When the surrounding temperature is below 4#, antifreeze fluid must be used for the cooling system of the tractor</p> <p>When the lowest surrounding temperature is above -15#, -25# long-acting antifreeze fluid (SH/T0521-1999) is used</p> <p>When the lowest surrounding temperature is above -25#, -35# long-acting antifreeze fluid (SH/T0521-1999) is used</p> <p>When the lowest surrounding temperature is above -35#, -45# long-acting antifreeze fluid (SH/T0521-1999) is used</p>
Gear Box, Rear Axle, Hydraulic Lifter Oil, Front Drive Axle, Steering Gear	MF1135 of Massey Ferguson or M2C 86A of Ford or J20A amphibious oil of John Deere can be used for the transmission system and lifter, hydraulic steering, central drive of front driving axle and final drive.
Oil Cup	The D-217 grease of National Lubricating Grease Institute (NLGI) is used and its viscosity grade is 2.
<p><b>Important:</b></p> <ol style="list-style-type: none"> <li>1. Before being used, dual-purpose transmission and hydraulic oil, diesel and diesel engine oil must go through the 48h precipitation period, so that machines can be protected from the entry of impurity and fault;</li> <li>2. The mixed use of oil from different trademarks and different manufacturers is strictly forbidden, so that the overall performance will not be affected;</li> </ol>	



**Warning:**

1. To avoid danger, do not refuel the fuel tank while operating the diesel engine;
2. If the tractor is working under the hot sun, the fuel tank should not be completely full, otherwise an accident will happen caused by overflowing fuel due to the inflation from the temperature. In the case that the oil is overflowing, it should be dried immediately to avoid it making contact with hot engine components.

**Important:** The cooling water should be clean soft water (such as rainwater, slush, river water and so on). If hard water (such as well water, spring water and so on) is to be used, it should be boiled before and added in the water tank post precipitation, so as to protect the water tank from damage.

## 11.2 List of Tightening Moment of Force for Main Bolts, Screws, and Nuts

Name and Assembly Position	Thread Specification	Tightening Moment of Force (N·m)
The bolt and screw nut connecting the engine and the clutch housing	M10	41~51
The bolt connecting the clutch housing and the rear axle casing	M14X1.5	123~154
The bolt fixing the bearing block of the primary shaft and the secondary shaft	M10	41~51
The bolt fixing the interlocking wedge	M10	50~70
The bolt fixing the slave drive spiral bevel gear	M10X1.25	45~55
The bolts connecting the drive shaft shell and the rear axle housing	M12×1.5	73~89
The bolt connecting the driving wheel hub and the radial plate	M18×1.5	397~457
The screw nut tightly locking the front shaft cross bar	M16X1.5	122~149
The bolt connecting the sub assembly of the front outer shaft and the front inner shaft	M14	122~149
The bolt connecting the front driving wheel, the front wheel hub, and the radial plate	M14×1.5	178~218

The bolt connecting the front axle and the bracket	M16	182~222
The bolt connecting the front bracket and the battery tray	M12	73~89
The bolt connecting the bracket and the engine	M12	73~89
The bolt connecting the bracket and the engine	M14X1.5	126~154
The bolt connecting the lifter shell and the rear axle housing	M10	41~51
The bolt connecting the steering gear and the clutch housing	M14	122~149
The coupling bolt of limited rod support	M14	122~149

**Warning:** When you tighten the main bolts and nuts, the tension wrench must be used to avoid danger like the decrease of overall performance, personal injury, etc. which may happen because the requirements of the tightening moment of force can not be met

### 11.3 Tractor's Rolling Bearings

No.	Code	Bearing Code	Bearing Name	Assembly Position	Number
1	GB/T 276	6203-Z	Deep Groove Ball Bearing	Front of the Clutch Shaft	1
2	GB/T 276	6006	Deep Groove Ball Bearing	Front of the Power Take-off Drive Shaft	1
3	GB/T 276	6206	Deep Groove Ball Bearing	Front of the Output Shaft of Transfer Case	1
4	GB/T 276	6207	Deep Groove Ball Bearing	Rear of the Power Take Off Shaft	1
				Driving Gear of the Intermediate Drive	2
5	GB/T 276	6208	Deep Groove Ball Bearing	Reduction Driving Gear at the End of Front Drive Axle	2
				Driven Gear of Intermediate Drive of Front Drive Axle	2
6	GB/T 276	6210	Deep Groove Ball Bearing	Outer End of the Drive Shaft	2
7	GB/T 276	6211	Deep Groove Ball Bearing	Inner End of the Drive Shaft	2
8	GB/T 276	6305	Deep Groove Ball Bearing	Rear of the Power Take-off Drive Shaft	1
				Front of the Power Take Off Shaft	1

				Rear of the Output Shaft of Transfer Case	1
9	GB/T 276	6307	Deep Groove Ball Bearing	Outer End of the Short Half Axle	2
10	GB/T 276	6207N	Deep Groove Ball Bearing	Front of the Primary Shaft of Transmission Box	1
11	GB/T 283	NT206E	Cylindrical Roller Bearing	Rear of the Primary Shaft of Transmission Box	1
12	GB/T 283	NUP2207E	Cylindrical Roller Bearing	Rear of the Secondary Shaft of Transmission Box	1
13	GB/T 297	31305	Cylindrical Roller Bearing	Front of the Secondary Shaft of Transmission Box	2
14	GB/T 297	32011	Cylindrical Roller Bearing	Both Ends of the Differential	2
15	GB/T 297	977907	Bearing	Lower End of the Steering Cam	1
		977,907K	Bearing	Upper End of the Steering Cam	1
16	GB/T 297	30205	Cylindrical Roller Bearing	Outer End of the Front Wheel Hub	2
17	GB/T 297	30206	Cylindrical Roller Bearing	Inner End of the Front Wheel Hub	2
18	GB/T 301	51106	One-way Thrust Ball Bearing	Vertical Shaft of Steering Knuckle	2
				Lower End of the Front Final Drive Shell	2
19		688711	Release Bearing	Release Bearing of Clutch	1
20	GB/T 5,846	K202,417	Needle Bearing	Intermediate Shaft of Transfer Case	2
21	GB/T 5,846	K25,3120	Needle Bearing	Output Shaft of Transfer Case	2
22	GB/T 5,846	K283,327	Needle Bearing	Driven Gear of Gear #~#	2
23	GB/T 5,846	K303,527	Needle Bearing	H-L Stationary Gear	2
24	GB/T 292	7,206AC	Angular Contact Ball Bearing	Inner End of the Front Drive Shaft	2
25	GB/T 292	7,208AC	Angular Contact Ball Bearing	Outer End of the Front Drive Shaft	2
26	GB/T 297	32007	Cylindrical Roller Bearing	Middle of the Mater Pinion Shaft	1
27	GB/T 297	32010	Cylindrical Roller Bearing	Front Axle Differential Shell	2
28	GB/T 297	32207	Cylindrical Roller Bearing	Front of Mater Pinion Shaft	1
29	GB/T 5,846	K424,822	Needle Bearing	Driving Gear of Gear #	1
				Driving Gear of Gear #	1

## 11.4 Sealing Elements of Tractor Chassis

Component	Specification	Assembly Position	Number	
Transmission Box	GB/T 9877.1 Rotary Shaft Lip Seal	B35×55×8	Front of the Primary Shaft	2
		FB35×55×8	Inside of the Bearing Cover of Power Take Off Shaft	2
		B50×72×8	Outside of Drive Shaft	6
		B55×75×8	Inside of the Drive Shaft	4
	JB/T2600 Skeleton Oil Seal	PD50×80×12	Driving Gear Shaft of the Final Drive	2
	GB/T3452.1 O-ring	11.8×1.8G	Shifting Fork Shaft of Power Take Off	1
		15×2.65G	Shifting Fork Shaft of the Differential Lock	1
		22.4×2.65G	Reverse Shaft	1
		28×3.55G	Driving Gear Shaft of the Final Drive	2
		67×3.55G	Front Bearing Block of the Secondary Shaft	1
		103×3.55G	Bearing Block of the Rear Axle	2
		112×3.55G	Drive Shaft Sleeve	2
Braker	GB/T3,452.1 O-ring	15×2.65G	Brake Camshaft	2
Front Shaft	Non-standard (Shown in the Drawing)	Vertical Axle Oil Seal 38×74×11.5	Lower End of the Steering Knuckle	2
		Half Axle Oil Seal 38×74×11.5	Front Wheel Hub	2
	GB/T3,452.1 O-ring	30×3.55G	Upper End of the Left and Right Steering Knuckle	2
			Both Ends of the Rocker Shaft	2
Steering Gear	GB/T9,877.1 Rotary Shaft Lip Seal	B30×45×8	Steering Pitman Arm Shaft	1
Lifter	JB/T2,600 Skeleton Oil Seal	PD42×62×10	Lift Shaft	2
	JB/T 982 Sealer	10×13.5	Oil Drain Plug	1
		10×13.5	Cylinder Head	2
		18×22	Position of Hydraulic Output Hollow Bolt	1
		36×42	Fuel Filling Breather Assembly	1
	GB/T3,452.1 O-ring	71×2.65G	Cylinder Sleeve and Housing Seal	1
		17×2.65G	Cylinder Head Adjusting Valve	1
		53×5.3G	Piston and Oil Cylinder	1
		53×5.3G	Piston and Oil Cylinder	1
Distributor	GB/T3,452.1 O-ring	9×2.65G	Handle Shaft, Safety Valve Seat	1

			Junction Surface of Lifter Shell	1
		13.2×2.65G	Impaction Screw Plunger of the Safety Valve	1
		15×2.65G	Junction Surface of Lifter Shell	1
		19×2.65G	Junction Surface of Lifter Shell	1
Oil Pump and Oil Passage	GB/T3,452.1	O-ring 18×2.65G	Suction Area of the Oil Pump	1
Transfer Case	JB/T2,600 Skeleton Oil Seal	SG30×45×8	Output Shaft of Transfer Case	1
	GB/T3,452.1 O-ring	12.5×1.8G	Shifting Fork Shaft of the Transfer Case	1
		36.5×2.65G	Front of the Rear Jacket Welding Parts	2
		53×2.65G	Rear of the Rear Jacket Welding Parts	1
Front Drive Axle	JB/T2,600 Skeleton Oil Seal	PG45×65×10	Oil Sealing Retainer	2
		SD45×70×10	Front Drive Shaft	2
		SD50×70×12	Lower End of the Vertical Shaft Sleeve	2
		W50×72×7	Lower End of the Vertical Shaft Sleeve	2
	GB/T 3452.1 O-ring	34.5×3.55G	Bearing Cover	2
		40×3.55G	Front Rocker Shaft	2
		33.5×3.55G	Mater Pinion Shaft	2
		56×2.65G	Dust Control Pipe Bracket	1
		67×3.55G	Front Rocker Shaft	2
		75×2.65G	Bearing Cover	2
			Outer End of the Half Axle Sleeve	2
		80×3.55G	Back Support	2
		85×3.55G	Bearing Block of the Mater Pinion Shaft	2
		170×3.55G	Drive Shaft Cover	2
175×3.55G	Inner End of the Half Axle Sleeve	2		

## 11.5 Supporting Farm Implements of AK404 Series Tractors

Category	Supporting Implement	Implement Model	Main Technical Specification

**Attention:** Before using the supporting farm implements, operators should carefully read the “Instructions for Use and Maintenance” and know the structure, performance, operational approach, and rational supporting as well to avoid damaging the implements and/or personal injury

### Notes:

1. Before choosing the farm implements, you should refer to this list and according to the working conditions (requirements of soil resistance, agronomy and so on) of the working area first choose the categories of supporting implements and then consult the distributors;
2. According to the purchased model of the tractor (power capacity) in combination with the working conditions (requirements of soil resistance, agronomy and so on) of the working area, you should refer to the results of the consultations to determine the models of farm implements you need for suitable support. If the supporting equipment is not suitable, it will have an adverse impact on the assembling units;
3. Different working conditions (requirements of soil resistance, agronomy and so on) with the same working efficiency of the implement can give different results. Please rationally define the working speed, working width etc. according to local working conditions.

## 12 Index

### A

Adjustment of Differential Lock

Adjustment of Tensioning Degree of Fan Belt

Appendices

Adjustment of Span between Rear Wheels

Adjustment of Driver Seat

Adjustment of Span between Front Wheels

Adjustment of Front-wheel Toe-in

Adjustment of Axial Clearance of Front Wheel Bearing

Adjustment of Side Drive of Front Drive Axle

Adjustment of Front Drive Axle

Adjustment of Central Drive of Front Drive Axle

Adjustment of Clutch (Single-acting)

Adjustment of Clutch (Double-acting)

Adjustment of Clutch

Adjustment of the Lowest Fall Position of Farm Implements

Adjustment of the Highest Lifting Position of Farm Implement

Accompanying Spare Parts

Adjustment of Trailer Air Brake

Adjustment of Hydraulic Lifting Mechanism

Adjustment of Contact Mouflage and Gear Backlash of Bevel Gear Pair

Adjustment of Brake

Adjustment of Central Drive

Adjustment of Steering Gear (Mechanical Steering)

Adjustment of Steering System

Adjustment of Cone Bearing Pre-tightened Amount

### B

Basis of Products' Warranty

Braking of Tractor

### C

Chassis Faults and Solutions

Check of Oil Mass of Engine Oil Pan and Changing of Oil

Check of Inflation Pressure of Tire

Check of Front Drive Oil Level

Control Mechanism of Tractor

Control Mechanism and Instrument of Tractor

Common Faults and Solutions of Tractor

D

Disassembly and Disposal

Details of Accessories, Spare Parts and Vulnerable Parts

Delivery, Acceptance, Transportation, Assembly and Installation

Delivery and Acceptance

Disassembly & Assembly of Tire

Detailed List of Accompanying Spare Parts

Dimension Drawing of Hitch System

E

Exhaust of Fuel System

F

Faults and Solutions of Electrical System

G

Gear Shifting of Tractor

H

Height Adjustment of Hydraulic Hitch System

Hydraulic Output and Use of Hydraulic Lock

I

Instructions

Idle Running in of Power Take Off Shaft

Idle Running in of Engine

Instruments and Switches

Idle and Loaded Running in of Tractor

L

List of Vulnerable Parts



## List of Accompanying Documents

### M

Maintenance of Transmission System

Maintenance of Oil Filter

Main Technical Specifications of 2-wheeled Drive Model of AK Series Tractors

Main Technical Specifications of 4-wheeled Drive Model of AK Series Tractors

Maintenance of Common Accumulator

Maintenance of Fuel Filter

Maintenance of Fuel Tank

Maintenance Instructions

Main Technical Specifications of 2-wheeled Drive Model of AK Series Tractors

Maintenance of Tractor During Sealing and Storage

Maintenance of Lifter

Maintenance of Oil Filter of Lifter

Maintenance of Tractor during Long-term Storage Period

Maintenance of Engine Cooling System

Maintenance of Oil-bath Air Filter

Main Technical Specifications of 4-wheeled Drive Model of AK Series Tractors

### O

Operation of Differential Lock

Operation and Use of Hydraulic Hitch System

Oil Use and Solution of Tractor

### P

Product Description

Product Model

Preparations before Running in

Position Adjustment

Preparations before Starting of Engine

### R

Running in of Hydraulic System

Running in of Tractor

Reasons for Damage of Tractor During Storage

Running of Engine

Rolling Bearing of Tractor

S

Safe Rules and Use Precautions

Safety Warning Sign

Safety Precautions

Situations of Unavailable Warranty

Storage

Starting of Engine

Starter Engine

Supporting Farm Implements of AK Series Tractors

Span between Front Wheels of 4-wheeled Drive Model

Sealing Elements of Tractor Chassis

Sealing and Storage of Tractor

Starting of Tractor

Stopping of Tractor and Flame-out of Engine

Steering of Tractor

Starting of Accumulator

T

Technical Maintenance Procedures

Technical Specifications

Technical Maintenance per Shift

Technical Maintenance after Running in

Technical Maintenance for Every 50h

Technical Maintenance for Every 200h

Technical Maintenance for Every 400h

Technical Maintenance for Every 800h

Technical Maintenance for Every 1,600h

Transportation

U

Use Technical Maintenance in Winter

Use of Electrical Equipment

Use of Multiple Unit Valve

Use and Maintenance of Dry-type Air Filter

Use of Tire

Use and Disassembly & Assembly of Tire

Unsealing of Tractor

Use of Counterweight

Use of Front Drive Axle

Use Precautions of Full Hydraulic Steering System

Unsealing of Tractor

Use of Hitch

W

Warranty Items



## AgKing QLD

Lot 2, 2 Summerholm Road,  
Hatton Vale, QLD, 4341

p: 0426 266 538

e: [sales@agking.com.au](mailto:sales@agking.com.au)

w: [www.agking.com.au](http://www.agking.com.au)

---

## AgKing WA

13 Lithic Way,  
Wangara WA 6065

e: [joe@agking.com.au](mailto:joe@agking.com.au)

w: [www.agking.com.au](http://www.agking.com.au)

---

## AgKing VIC

Unit 1 – 145 Wimble Street,  
Seymour VIC 3660

p: (03) 5979 8988

e: [sam@agking.com.au](mailto:sam@agking.com.au)

w: [www.agking.com.au](http://www.agking.com.au)

---